

NOMINAL PIPE SIZE	FLANGE D	Hub			Hub m	Raised Face a	Raised Face g	Drilling Template Number	Drilling Template		Weight Kg
		J	b	h					k	l	
1/2"	88.9	15.75	11.1	47.6	30.2	21.3	34.9	4	60.3	15.9	0.5
3/4"	98.4	20.8	12.7	52.4	38.1	26.7	42.9	4	69.8	15.9	0.7
1"	107.9	26.7	14.3	55.6	49.2	33.5	50.8	4	79.4	15.9	1.1
1 1/4"	117.5	35.05	15.9	57.1	58.7	42.2	63.5	4	88.9	15.9	1.5
1 1/2"	127	40.9	17.5	61.9	65.1	48.3	73	4	98.4	15.9	1.8
2"	152.4	52.6	19	63.5	77.8	60.4	92.1	4	120.6	19	2.7
2 1/2"	177.8	62.7	22.2	69.8	90.5	73.1	104.8	4	139.7	19	4.4
3"	190.5	78	23.8	69.8	107.9	88.9	127	4	152.4	19	5.2
3 1/2"	215.9	90.2	23.8	71.4	122.2	101.6	139.7	8	177.8	19	6.4
4"	228.6	102.4	23.8	76.2	134.9	114.3	157.2	8	190.5	19	7.5

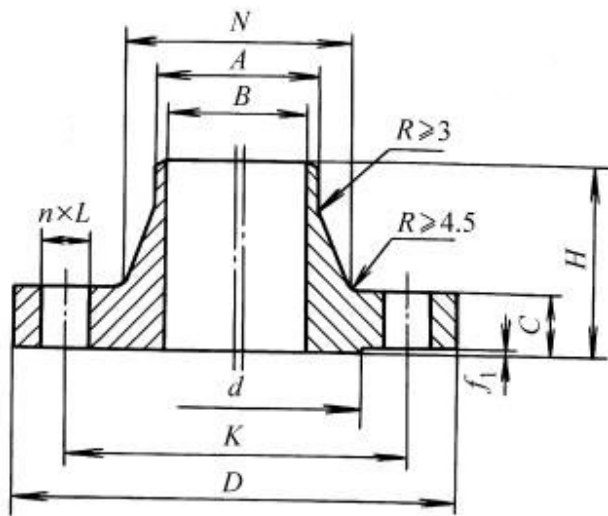

PN ≤ 5.0 MPa

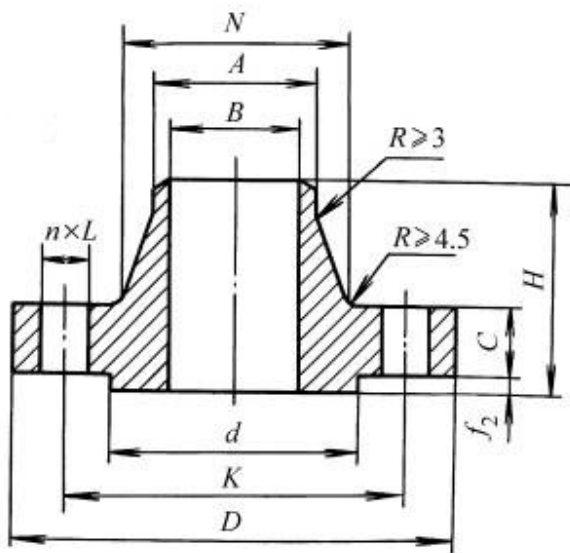
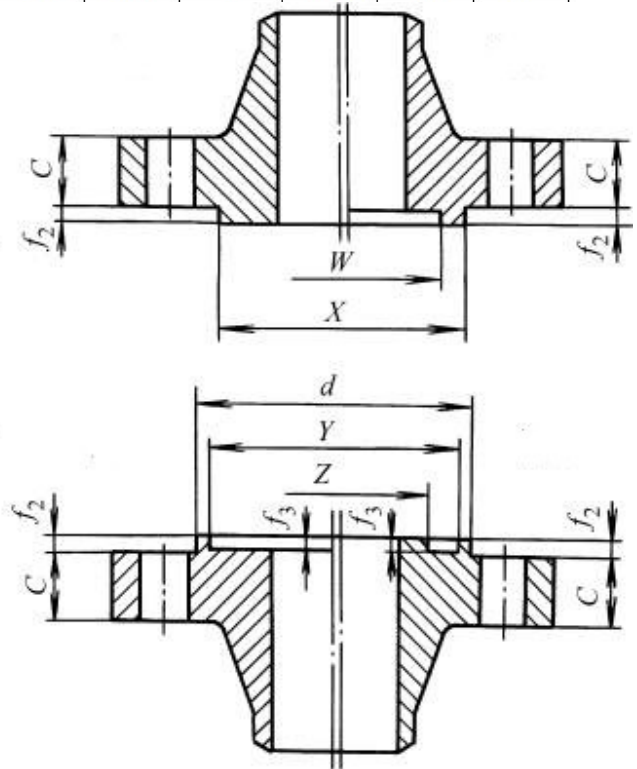

PN ≥ 11.0 MPa

