

**I-SYS R5.0V1 WEIGH BRIDGE PCB CONNECTION DETAILS**

Only for R5.0V1 model

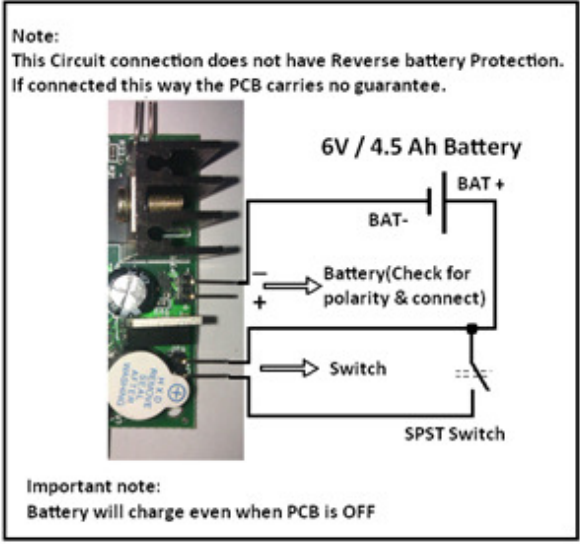
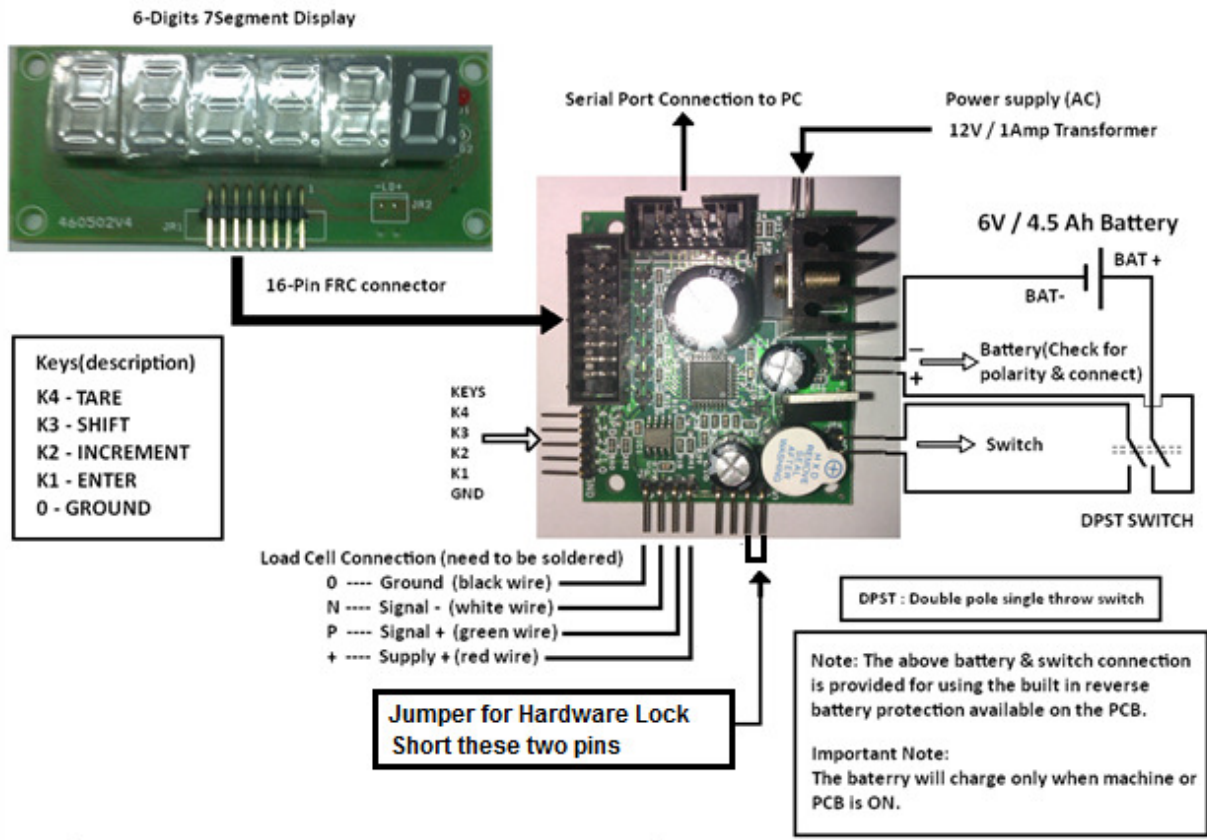

## Weigh Bridge PCB Configuration & Calibration Manual

To configure the machine, connect the power supply. Short the jumper pins as shown in the above circuit provided for hardware lock. Now press **TARE key(K4)** and with the TARE key(K4) pressed power on the Machine (switch connected to the weighing PCB).

It shows

P	0	0	0	0	0.
---	---	---	---	---	----

Now use the **INCREMENT key(K2)** & **SHIFT key(K3)** to enter the Password given to you & then press the **ENTER key(K1)**. If your Password is wrong it will display "Sorry".

If you have entered the right Password it shows

P	A	R	A		
---	---	---	---	--	--

Now press ENTER key(K1) to go to parameters (PARA) settings

Or press Increment (INC) key(K2) to change to (CAL)

calibration settings.

To configure PARA press enter key when it displays "PARA".

It'll display "CAP" as shown below for a brief period...

C	A	P			
---	---	---	--	--	--

This means capacity.

0	0	0	0	0	0.
---	---	---	---	---	----

Enter the maximum capacity.

To set maximum Capacity use INC key(K2) and SHIFT key(K3).

Ex: for 30kgs

L	0	0	0	3	0.
---	---	---	---	---	----

Enter the maximum Load & then Press ENTER key(K1).

The next option is PSEL (Parameter / Function selection)

P	S	E	L		0.
---	---	---	---	--	----

In this there are two modes.

PSEL 0— for Normal weighing ; PSEL 1— for Tank Weighing mode. In tank weighing mode, upon power-on the machine will not zero & will display the exact weight on the weigh bridge.

The next setting is the Scale's Least Count settings, LC1 & LC2.

LC1 is for least count 1 and is applicable from zero load to 50% of machine capacity. LC2 is for least count 2 & applies for load greater than 50% to maximum capacity of the scale.

L	C	x			0.
---	---	---	--	--	----

LCx 0—increment of resolution in steps of 1 count accuracy

LCx 1—increment in steps of 2 counts.

LCx 2—increment in steps of 5 counts.

LCx 3—increment in steps of 10 counts.

LCx 4—increment in steps of 20 counts.

LCx 5—increment in steps of 50 counts.

LCx 6—increment in steps of 100 counts.

AT0 - is for auto-zero. You can enter values 0 to 9. Small drift in weight seen in the least significant digit is zeroed for values less than or equal to multiples of AT0 value we have entered. For most purpose set it to a value in the range of 3 to 5.

The auto-zero counts = AT0 value \* least count(LC).

Press INC key(K2) to change the value & use ENTER key(K1) to accept the value.

A	t	0			5.
---	---	---	--	--	----

In this case the auto-zero counts = 5 \* LC.

D0 - is Dummy-zero. Enter the value 1 to invoke dummy-zero. It works in range 2(set in calibration routine for 100kg to 999 kg range) and it shifts the display digit to the left side to place a dummy zero.

To select dummy-zero press INC key(K2) & set D0 – 1 and then press ENTER key(K1).

D	0				0.
---	---	--	--	--	----

Unit: 0-4. It is used to specify the units like milligram or kilo-newton of the scale for serial print / communication.

Unit: 0-(mg); 1-(g); 2-(kg); 3-(ton "t"); 4-(kilo-newton "kn"). This is used only for serial output (UART) application.

U	n	i	t		0.
---	---	---	---	--	----

Press ENTER key(k1).

F	I	L			0.
---	---	---	--	--	----

Now you can select the filter options. Use default "0" for fast response. Higher values of filter can be used for platform scales & weigh bridge application where there is a lot of movement or oscillations on the platform. You are provided with 4 settings(0 – 3) option for filter. Choose the one most suitable for your application.

Next we can choose different banner or start-up display options.

S	d	I	S		0.
---	---	---	---	--	----

The various display options are scrolling name display, 123... display or a combination of both. Select values 0,1,2 & see the difference for yourself.

Next is power save option.

P	S				0.
---	---	--	--	--	----

We recommend you to use default value "0" to save power (single zero display in power save mode).

Entering value "1" will display all digits even when weight is zero (No power saved).

Next we have serial communication options...

C	O	n	n		0.
---	---	---	---	--	----

COM 0 – for continuous serial dump. COM 1 – for transmit on request mode.

In request mode the PCB will send weight data only if it receives ascii value "5" from the master.

Next we have baud rate selection for the serial communication(UART).

B	A	U	d		0.
---	---	---	---	--	----

BAUd 0 – for 2400 baud. BAUd 1 – 9600 baud.

Next we can select the parity ( No parity bit, even parity bit, or odd parity bit).

P	r	y			0.
---	---	---	--	--	----

Pry 0 – for 8 data bit, no parity, 1 stop bit, Pry 1 – for 7 data bit, odd parity bit, 1 stop bit, Pry 2 – for 7 data bit, even parity bit, one stop bit.

Now we have completed configuring all the setting in the "PARA" menu.

Once all the settings in PARA menu is completed it will again return back to the main menu "PARA".

When PARA appears as below you are ready to calibrate the machine.

P	A	R	A		
---	---	---	---	--	--

To enter into calibration mode press INC key(K2).

0	-	C	A	L	
---	---	---	---	---	--

It will appear as shown.

It represents "0" calibration of the machine. Press ENTER key(K1) & it will display the zero weight count or no-load counts of the machine as shown below...

	0	x	x	x	x.
--	---	---	---	---	----

"x" represent any number from 0 to 9. The **no load counts** should generally be less than 9000 counts. Once the counts become stable press the ENTER key(K1) to accept the **no load counts** value.

Next it'll show 0-CAL again as below...

0	-	C	A	L	
---	---	---	---	---	--

Press INC key(K2).

Next it'll show L-CAL as shown below...

L	-	C	A	L	
---	---	---	---	---	--

It represents Load Calibration.

Now press Enter key(K1).

Next "rAnGEx" will appear. This selection decides the decimal point position.

RANGE 0-4(range selection)

R	A	N	G	E	0.
R	A	N	G	E	1.
R	A	N	G	E	2.
R	A	N	G	E	3.
R	A	N	G	E	4.

Displayed output

-	0.	0	0	0	0
-	0	0.	0	0	0
-	0	0	0.	0	0
-	0	0	0	0.	0
-	0	0	0	0	0

Use the INC key(K2) to change the range value.

Select and press ENTER key(K1).

Next it will display "**LOAD**" briefly as below.

L	O	A	D		
---	---	---	---	--	--

And then it will again display the No-load count value.

Now you need to place a **known-load** (Standard calibration Weight) on the weigh Bridge.

It will now show the **known-load count value**.

	Y	Y	Y	Y	Y
--	---	---	---	---	---

Press the Enter key(K1) to accept the known-load count value.

The display will now display the span value (**known-load count value – no-load count value**) for a brief period & then it will display as below...

	0	0.	0	0	0
--	---	----	---	---	---

The decimal point position will depend on your range value selected earlier.

Using the INC key(K2) & SHIFT key(K3) enter the known-weight(Calibrating weight)you had kept on the weigh bridge just now to calibrate. Example...

	0	2.	0	0	0
--	---	----	---	---	---

Enter the value for the known weight and press ENTER key(K1).  
Next remove the known-weight from the platform.

It will now show "L-CAL" again. Now your calibration procedure is completed.

If you want to check if your calibration is right, you can now press INC key(K2) to switch to "t-CAL" function.

It'll display as shown below...

t	-	C	A	L	
---	---	---	---	---	--

Press ENTER key(K1).

It'll display the actual weight on the platform. If there is an error in the actual weight, press ENTER key(K1) & it'll display "EntEr" for a brief period & display...

	0	0.	0	0	0
--	---	----	---	---	---

You can now enter the actual weight kept on the platform once again as shown below...

	0	2.	0	0	0
--	---	----	---	---	---

Press ENTER key(K1) to accept the value. This is useful for fine tuning your calibration values for better accuracy.

Now please switch OFF the power to the PCB & then switch it ON.

Your machine is calibrated & ready to use.

You can also access "t-CAL" function from weighing mode by a long press of SHIFT key(K3) & the procedure to fine tune calibration is same as described above.

If you had selected PSEL – 1, you have set the machine in tank weighing mode & the machine will retain & display the actual weight on the platform even after power failure & resumption. Special set-point (with relay output control) PCBs are available. Please contact manufacturer for more information.

**TARE / ZERO Limit:** The machine has 4% of maximum capacity as the TARE / ZERO limit, beyond which the machine will display "-0-error" as shown below...

-	0	-	E	r	r
---	---	---	---	---	---

This helps detection of faulty or failed load-cell in the weigh bridge.

For more information regarding calibration & settings please call the manufacturer.

**Serial Communication:** A 10 pin FRC box header with TTL UART Pins are available for serial communication. RS232 adaptor PCBs as shown below are available for easy interface for connecting to a PC.

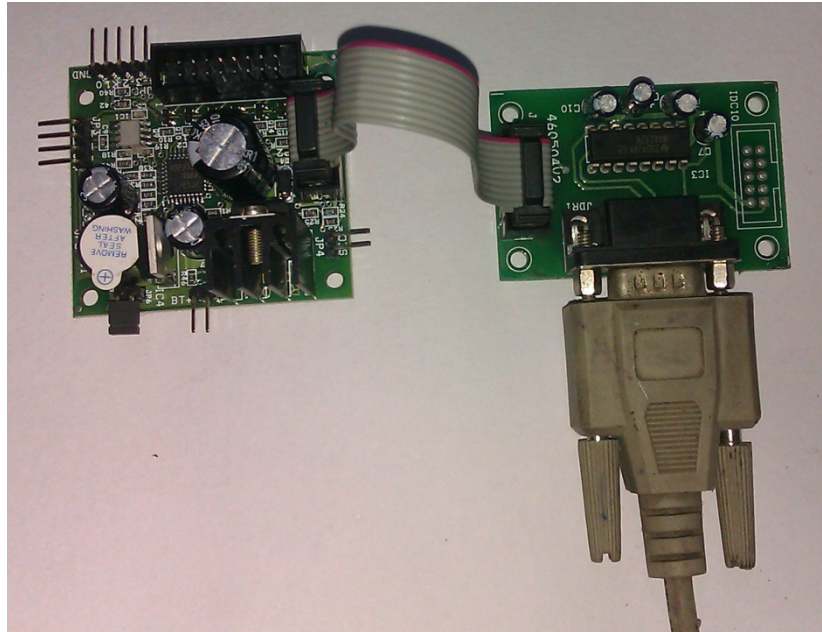

The communication settings are as follows...

Continuous or Request mode: Selectable.

Baud Rate: 2400bps or 9600bps selectable.

Parity: None, Even, Odd.

Data length: 8 data bit no parity one stop bit, 7 data bit odd parity one stop bit, 7 data bit even parity one stop bit.

Hardware flow: None

For customized string format, please contact manufacturer. Optically isolated RS232 /485 interface PCBs are also available with us.

The data string will be a continuous dump data or transmit on request. The data rate is 10 data strings per second for continuous dump.

Example of a serial string data is as shown below...

**#+000.000 kg\$202**

The data after the “#” is the weight data. The data after “\$” is the battery ADC data, used in debugging battery voltage condition.

**LED Display:** 6 digit Common anode seven segment display. A 16pin FRC box connector is provided on the PCB for this purpose. Apart from segment (weight) display it will also drive a LED that indicates the presence of mains supply.

**Buzzer annunciation:** The buzzer is used for multiple annunciations. A few are mentioned below...

- a. Beeps with scrolling banner display.
- b. Beeps while TARE key is pressed.
- c. Intermittent & continuous beeps for set-point1 & set-point2 function.

External I/O pins: 3 controller pins are available for input / output control application.  
Please contact manufacturer for customization of program for i/o pin control applications.

**Contact Address:**

**i-sys**

**# 1, 12<sup>th</sup> East Street, Kamaraj Nagar,**

**Thiruvanmiyur, Chennai - 600041**

**India.**

**Phone : 04424485884**

**Mobile : 09841047643**