

**I-SYS WEIGHING SCALE PCB CONNECTION DETAILS**  
**ONLY FOR MODELS SDK-V1, SAP-V1**

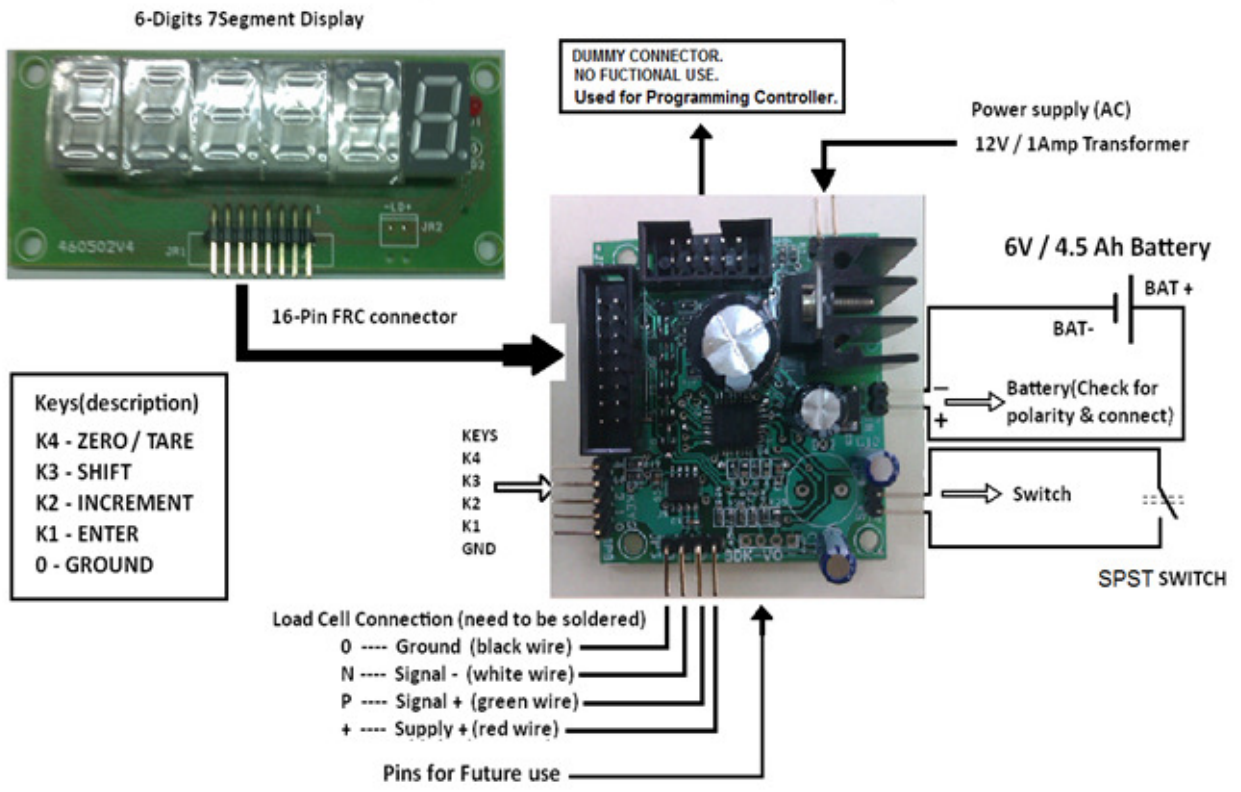

# SDK-Vx, SAP-Vx PCB Configuration & Calibration Manual

To configure the machine, connect the power supply. Now press TARE key(K4) and with the TARE key(K4) pressed power on the Machine (switch connected to the weighing scale PCB).

It shows

P	0	0	0	0	0.
---	---	---	---	---	----

Now use the INCREMENT key(K2) & SHIFT key(K3) to enter the Password given to you & then press the ENTER key(K1). If your Password is wrong it will display “Sorry”.

If you have entered the right Password it shows

P	A	R	A		
---	---	---	---	--	--

Now press ENTER key(K1) to go to parameters (PARA) settings  
Or press Increment (INC) key(K2) to change to (CAL)  
calibration settings.

To configure PARA press enter key when it displays “PARA”.

L	0	0	0	0	0.
---	---	---	---	---	----

To set maximum Capacity use INC key(K2) and SHIFT key(K3).

Ex: for 30kgs

L	0	0	0	3	0.
---	---	---	---	---	----

Enter the maximum Load & then Press ENTER key(K1).

The next setting is the Scale’s Least Count settings, LC1 & LC2.

LC1 is for least count 1 and & is applicable form zero load to 50% of machine capacity. LC2 is for least count 2 & applies for load greater than 50% to maximum capacity of the scale.

L	C	x			0.
---	---	---	--	--	----

LCx 0—increment of resolution in steps of 1 count accuracy

LCx 1—increment in steps of 2 counts.

LCx 2—increment in steps of 5 counts.

LCx 3—increment in steps of 10 counts.

AT0 - is for auto-zero. You can enter values 0 to 9. Small drift in weight seen in the least significant digit is zeroed for values less than or equal to AT0 value we have entered. For most purpose set it to a value in the range of 3 to 5.

Press INC key(K2) to change the value

A	t	0			5.
---	---	---	--	--	----

D0 - is Dummy-zero. Enter the value 1 to invoke dummy-zero. It works in range 2(set in calibration routine for 100kg to 999 kg range) and it shifts the display digit to the left side to place a dummy zero.

To select dummy-zero press INC key(K2) & set D0 – 1 and then press ENTER key(K1).

D	0				0.
---	---	--	--	--	----

Digital Filter options:

F	I	L			0.
---	---	---	--	--	----

Now you can select the filter options “FIL”. Use default “0” for fast response. Higher values of filter can be used for platform scales & weigh bridge application where there is a lot of movement or oscillations on the platform.

Now we have completed configuring all the setting in the “PARA” menu.

Once all the settings in PARA menu is completed it will again return back to the main menu “PARA”.

When PARA appears as below you are ready to calibrate the machine.

P	A	R	A		
---	---	---	---	--	--

To enter into calibration mode press INC key(K2).

C	A	L			
---	---	---	--	--	--

It will appear as shown.

Now press Enter key(K1).

Next “rAnGEx” will appear. This selection decides the decimal point position.

RANGE 0-4(range selection)

R	A	N	G	E	0.
R	A	N	G	E	1.
R	A	N	G	E	2.
R	A	N	G	E	3.
R	A	N	G	E	4.

Displayed output

-	0.	0	0	0	0
-	0	0.	0	0	0
-	0	0	0.	0	0
-	0	0	0	0.	0
-	0	0	0	0	0

Use the INC key(K2) to change the range value.

Select and press ENTER key(K1).

Next it shows **No-Load count** value.

	X	X	X	X	X
--	---	---	---	---	---

Now press the Enter key(K1) to accept the **No-load count value**.

Next it will display “**LOAD**” briefly as below.

L	O	A	D		
---	---	---	---	--	--

And then it will again display the No-load count value.

Now you need to place a **known-load** (Standard calibration Weight) on the pan.

It will now show the **known-load count value**.

	Y	Y	Y	Y	Y
--	---	---	---	---	---

Press the Enter key(K1) to accept the known-load count value.

The display will now display the span value (known-load count value – no-load count value) for a brief period & then it will display as below...

	0	0.	0	0	0
--	---	----	---	---	---

The decimal point position will depend on your range value selected earlier.

Using the INC key(K2) & SHIFT key(K3) enter the known-weight (Calibrating weight)you had kept on the pan just now to calibrate. Example...

	0	2.	0	0	0
--	---	----	---	---	---

Enter the value for the known weight and press ENTER key(K1).

Next remove the known-weight from the pan.

It will now show “CAL” again. Now your calibration procedure is completed.

Now please switch OFF the power to the PCB & then switch it ON.

Your machine is calibrated & ready to use.

In the weighing mode, if you press the INC key(K2), it will display the battery voltage as shown below.

b			6.	5	1
---	--	--	----	---	---

It means the battery voltage is 6.51 Volts. This function is very useful to check if your battery is ok or not.

This board does not have serial communication interface.

For more information regarding calibration & settings please call the manufacturer.

Contact Address:

**i-sys**

**# 1, 12<sup>th</sup> East Street, Kamaraj Nagar,**

**Thiruvanmiyur, Chennai – 600041**

**India.**

**Phone : 04424485884**

**Mobile : 09841047643**