

Riser Clamp

Catalogue Number : 8000107 : Rev. 01 Dated 07-10-2014

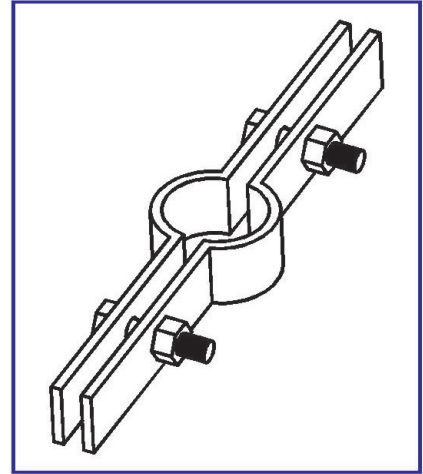
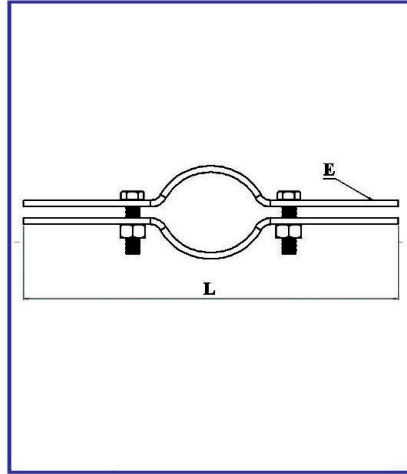

SELECTION TABLE (Table No: B-17-01)

Part No.	Pipe Size	Length (L)	Metal Size (mm) (E)	Bolt Size	Max Load Kgs
SRC022	½"	200	4x25	M10	80
SRC028	¾"	210	4x25	M10	90
SRC035	1"	230	4x25	M10	100
SRC040	1 ¼"	260	4x25	M10	120
SRC048	1 ½"	260	4x25	M10	120
SRC060	2"	260	4x25	M10	150
SRC075	2 ½"	290	4x38	M12	200
SRC090	3"	290	4x38	M12	250
SRC100	3 ½"	330	4x38	M12	350
SRC115	4"	330	4x38	M12	350
SRC140	5"	350	6x38	M16	550
SRC168	6"	380	6x38	M16	700
SRC220	8"	470	8x38	M16	900
SRC273	10"	520	10x50	M16	1100
SRC323	12"	580	12x50	M20	1100
SRC355	14"	610	12x50	M20	1600
SRC406	16"	660	16x60	M20	1600
SRC457	18"	710	16x60	M20	1900
SRC508	20"	760	16x60	M20	1900
SRC610	24"	880	16x75	M20	2400
SRC762	30"	1040	16x75	M20	2400
SRC915	36"	1210	16x100	M25	3200

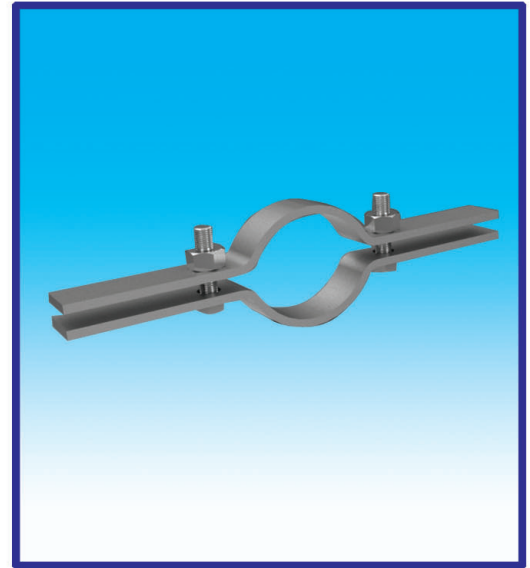

Riser Clamp

1. Compliance:

- a) Federal Specification AS-A-1192 (Type 1)
- b) MSS-SP58 (Type 1)
- c) MSS-SP69
- d) WW-H-171E (Type 1)
- e) EG-ASTMB 633 SC3, BS 1706 FE / ZN 12

2. Material:

Mild Steel ElectroGalvanised.

3. Application:

Guide and provide rigid support and ensuring stability under large lateral load for all types of vertical piping.

4. Features:

When used as pipe guides, lateral stability is ensured while permitting axial thermal expansion / contraction.

5. Selection / Ordering:

- a) Pipe OD and material plus insulation thickness.
- b) Hot Dip Galvanised Finish (Suffix "HDG")
- c) EPDM Lined (Suffix "R")
- d) Epoxy Powder Coated Finish (Suffix "P")
- e) Stainless Steel Construction (Suffix "SS")

Note:

- Due to policy of continual improvement, the specifications are subject to change without prior notice
- Measurements are subject to 5% tolerance

