

Note: please read the instruction book carefully before installing the driver

I Performance and features

- Microstepping control: step motor can be operated and located for 1,1/2,1/4.....1/256, 1/5,1/10.....1/50 origin step angle, so the control accuracy is increased and the defect of rough running and easy to out-of-step operation in low speed is overcome.
- Smooth-subdivision control: minimum positioning accuracy is still the origin step angle of motor, but smooth-subdivision transition is used between steps to overcome the defect of rough running and easy to out-of-step operation in low speed.
- High speed and high torque: the slaving voltage of power amplifier is DC140V, so high-torque output is obtained in high speed.
- New technique: control core consists of Single Chip Microcomputer and programmable array, good control performance; large power IGBT amplifier tube made by Fairchild Co. in USA, strong overload and overheat ability, hard to burnout.
- High reliability: high integrated level of control circuit, few connecting lines, dust-proof structure, protection of over temperature, over current and under voltage.

II Technical data

Power input: AC110V/5A

Adapted motor:110~130 series two-phase hybrid stepping motor

Step angle subdivision: 1:1, 1:2.....,1:10,1:20 Look the table

Input signal: impulse (CP)direction (CW), enable (FREE)

Signal level:5V,3~15mA, 1K resistance series in 12V, 2K resistance series in 24V Maximum input pulse frequency: 50K

Minimum input pulse width: 10uS

III Interface and dial switch (DIP)

1. Tables of Interfaces

Signal interface table

PIN	Terminal name	Description
1	CP+	Pulse (+) Input
2	CP-	Pulse (-) Input
3	DIR+	Direction (+)Input
4	DIR-	Direction (-)Input
5	FREE+	Power down (+) Input
6	FREE-	Power down (-) Input

Motor interface table :

Terminal name	Description
A	head of phase A
— A	end of phase A
B	head of phase B
— B	end of phase B

power interface table :

Terminal name	Description
AC	AC110input
AC	AC110 input
PE	Power Grand

Microstepping Motor Driver SEA-1108

2 Setting of dial switch

Setting current

switch : ON=0 , OFF=1																
1	0	0	0	0	0	0	0	0	1	1	1	1	1	1	1	1
2	0	0	0	0	1	1	1	1	0	0	0	0	1	1	1	1
3	0	0	1	1	0	0	1	1	0	0	1	1	0	0	1	1
4	0	1	0	1	0	1	0	1	0	1	0	1	0	1	0	1
current (A)	0.5	1.0	1.5	2.0	2.5	3.0	3.5	4.0	4.5	5.0	5.5	6.0	6.5	7.0	7.5	8.0

Microstepping Setting

switch : ON=0 , OFF=1																
7	0	0	0	0	0	0	0	0	1	1	1	1	1	1	1	1
8	0	0	0	0	1	1	1	1	0	0	0	0	1	1	1	1
9	0	0	1	1	0	0	1	1	0	0	1	1	0	0	1	1
10	0	1	0	1	0	1	0	1	0	1	0	1	0	1	0	1
micro	1	2	4	5	6	8	10	16	18	20	32	40	50	64	128	256

Switch6:Empty

Switch5:

the half current enable.

”ON”=0-----unable;

”OFF”=1-----enable

IV Schematic diagram of interfaces

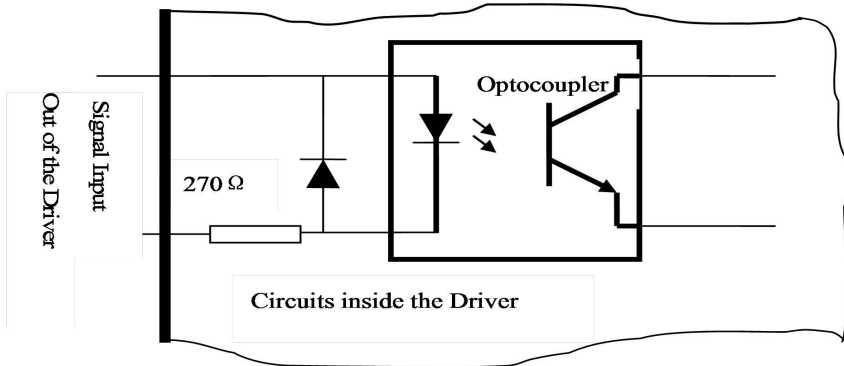

V Installation

1. Open and check

CW1108 driver is enclosed with plastic connectors, please open the box and check the connectors, If not coincidental, please contact us for settlement immediately.

2. Installation

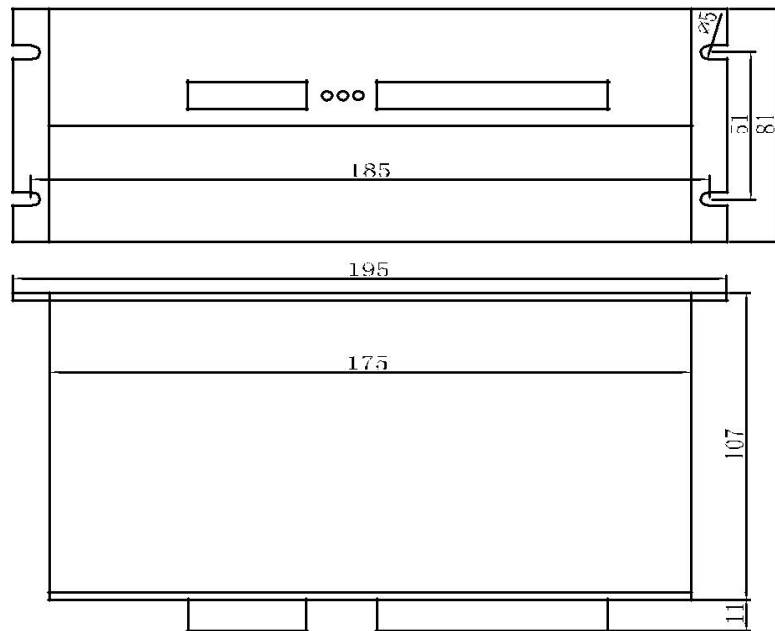

Microstepping Motor Driver

SEA-1108

3. Wiring

Please connect wires according to interfere table and schematic diagram of interfaces. The sectional area of power wire and motor wire should be greater than 1 square millimeter. Make sure that wiring joint is firm. Prevent joint from heating to destroy parts and cause driver work abnormally, and attention good ground connection.

VI Fault detection

When the system has fault, how do we confirm that it aroused by the driver or not? “Substitution method” can do it. This means that a new driver substitutes a “bad” one. After the substitution, if the system returns to normal condition, it is identified that the driver is bad. Otherwise, other parts but the driver should be checked. But, the following cases are not caused by bad driver, please note:

Insulating transformer

Fault case	Fault cause
Having power amplification, But the electromotor can't run	No CP, signal input or its polarity reverse.
Electromotor can only run to one way	Wrong U/D input:
The electromotor can work normally, but it may lose steps.	(1) The controller control rise and drop is too fast. (2) Mechanical system is not smooth or overloaded (3) Electromotor resonate (4) Electromotor or connecting circuit has phenomenon of leakage or poor contact

Note: As to lose step because of resonance, adjusting the damping disk in back cover of the electromotor can solve it. If the driver is damaged, please contact manufacturer for repair