

Technical Specifications

Model	SI-810PRSS	SI-810PR
Capacity / Accuracy	6kg/1g	15kg/2g 31kg/5g
Resolution	1/6000	1/7500 1/6200
Display Type	Graphical Dot Matrix LCD with Green Back Light	
No. of keys	Total Keys - 55 tact switch, Preset keys - 30 x 3	
Memory capacity	2MB	
Processor	32-bit ARM processor	
Power source	Power Supply - 230V AC,50Hz,30W MAX	
Battery	12V/3.4Ah Rechargeable	
Standard interface	2 X USB Port Interface Keyboard/Scanner, RS232 - 1Nos.	
Factory option	Ethernet Interface	
Paper width	2 Inch direct thermal	
Printing speed	50mm/sec	
Paper size	Paper Width 57.5mm, Maximum 40mm dia	
Application Software	PLU Mapping, PLU Manager, User Manager, Backup etc.	
Reports	Total sales, PLU sales, Department sales, Group sales, Hourly sales, Operator sales, Bill summary, Inventory, PLU Price override, Bill cancellation, PLU Reference, PLU Re-order, Non-Cash, Total sales summary.	
Dimensions (mm)	Total machine dimension 373mm(L) X 350mm(W) X 480mm(H) Platform Size (mm) - 275(W) X 350(L)	490mm(L) X 360mm(W) X 450mm(H)
material of construction	Fully SS	Top housing plastic Base Plate: MS powder coated

Optional interface

Ethernet

External Dimensions

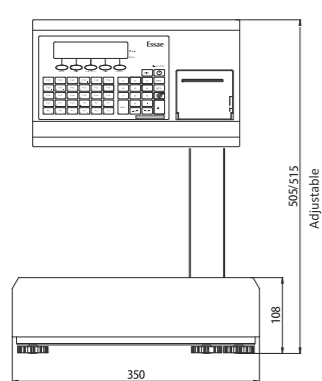

SI-810PRSS

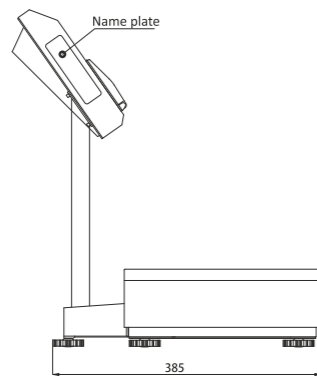

SI-810PR

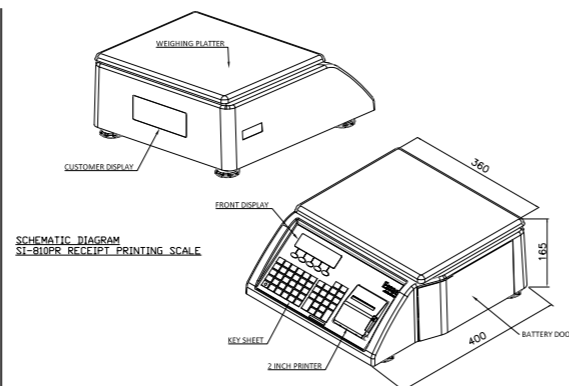

Form No. CAT-SI-810PR-030 R09

www.essae.com

Essae[®]
...for Excellence



SI-810PR Series
Receipt Printing Scale

Salient Features



Powerful 32-bit **ARM** Processor



Full Stainless Steel (SS-304) Construction



Elevated thermal printer to work in any demanding environment

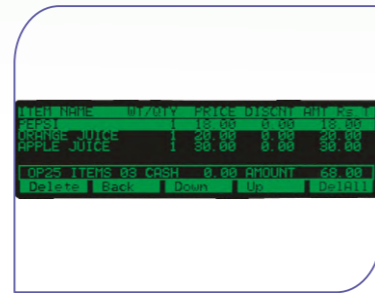

Graphical LCD display for easy readability



Battery

Rechargeable battery for un-interrupted and smooth operation



Customer display with Interface ports



30 x 3 Preset / Hot keys for fast moving items

Head quarter - Store network communication



Sample Print out

Bill

ESSAE-TERAOKA
No.377/22,8th Cross,
VI Ison Garden,
Banga lore-27.

09/08/10 15:30 Operator 25
MCSI810/01 BILL#00002

ITEM NAME	WT/QTY	PRICE	AMT Rs.
ONION	2.050	25.00	51.25A
TEA	1	8.00	8.00
MIRINDA	1	12.50	12.50
APPLE	2.050	120.00	246.00B
BADAM MILK	6	11.00	66.00
PEPSI	10	12.00	120.00
GRAPES	2.745	40.00	109.80B
TAX A @ 12.50%		5.69	
TAX B @ 4.00%			14.23
TAX TOTAL			19.92
ST DISCOUNT			627.78
ROUND OFF			-28.00
			0.22
Rs.			600.00
CQ			500.00
VU			100.00
TOTAL SAVINGS Rs.			28.00
T QTY: 18pcs. T WT: 6.845kg			
NO OF ITEMS: 7			

Thank You
Visit Again

Reports

ESSAE-TERAOKA
No.377/22,8th Cross,
VI Ison Garden,
Banga lore-27.

PLU SALES REPORT

09/08/10 15:12 To 09/08/10 15:38
MCSI810/01
PLU'S FROM 1 TO 9999

PLU#	PLU NAME	WT/QTY	AMOUNT Rs.
1	PEPSI		
2	COKE	10	120.00
3	MIRINDA	1	11.80
4	COFFEE	2	25.00
5	TEA	1	10.00
6	BADAM MILK	1	8.00
7		7	77.00
9	GRAPES	2.050	246.00 B
10	ONION	2.745	109.80 B
12	TAMATO	2.050	51.25 A
		0.775	10.85
9908	PLU Name 9908	0.775	34.88
9909	PLU Name 9909	2	240.00
TAX A @ 12.50%		5.69	
TAX B @ 4.00% EXCL.			14.23
TAX TOTAL			19.92
ST DISCOUNTS			968.51
TOTAL ROUND OFF			-28.00
			-0.01
Rs.			930.50
NO OF PLU'S			12

Thank You
Visit Again

ESSAE-TERAOKA
No.377/22,8th Cross,
VI Ison Garden,
Banga lore-27.

TOTAL SALES REPORT

09/08/10 15:12 To 09/08/10 15:38
MCSI810/01

TRANSACTION	COUNT	AMOUNT Rs.
BILLS	4	1071.00
BILLS CANCELLED	1	-120.50
REFUNDS	2	-20.00
Rs.		930.50
RECEIVED ON ACC	1	1000.00
PAID OUT	1	-50.00

IN CASH DRAWER

Rs. 1,880.50

By Cash	2	980.50
By Voucher	1	100.00
By Cheque	1	500.00
By CreditCard	1	300.00
ST DISCNTS	1	-28.00
T.ROUND OFF	2	-0.01

TAX SUMMARY

TAX A @ 12.50% INCL.	5.69
TAX B @ 4.00%	14.23
TAX TOTAL	Rs. 19.92

Thank You
Visit Again