

AIR BLOW GUN

Series WB

Cat No WB - 01 - 01

AIR BLOW GUN

Features

- Easy handling
- Compact size
- Attractive design
- Good flow and characteristics

Applications

- Blowing off chips in machine tools
- Foundries
- Assembly lines
- Service stations
- Painting (part cleaning)
- Textile mills
- Injection moulding machines (cooling of moulds)
- Pressure die casting machines



Technical Specifications

Ordering no	WB101
Medium	Compressed air
Maximum pressure	8 bar *
Inlet connection	G1/4

* For safety purpose it is strongly recommended to use the air blow gun at air pressure of 2 bar to 3 bar.

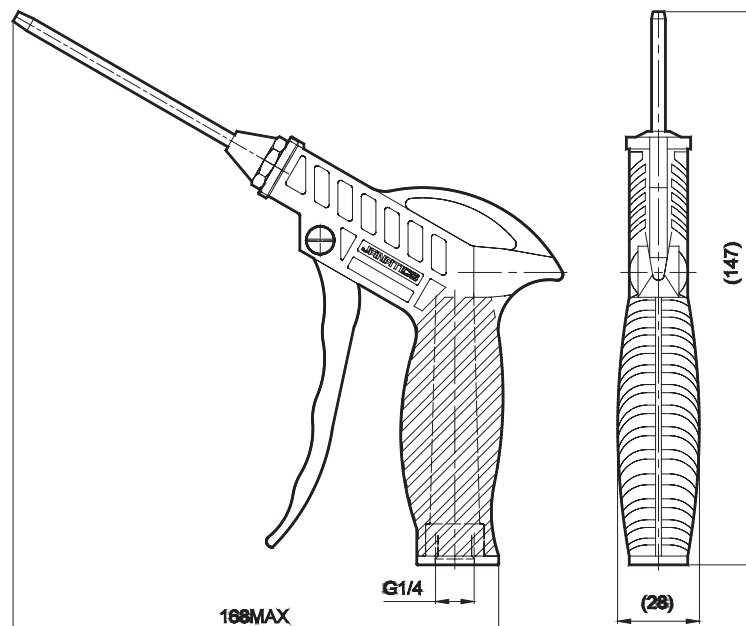

Subject to change