

AIR CYLINDER

Series A51, A52

Cat No A51 - 03

AIR CYLINDERS Double Acting Ø (12 - 25) mm

As per ISO 6432 / CETOP RP52P standards

Features

- Elastomer cushioning at both ends.
- Wide varieties of mountings.
- Low friction.
- Long life.



AIR CYLINDERS Double Acting Ø (12 - 25) mm

Technical Specifications

Bore dia (mm)	12	16	20
Standard strokes * (mm)	25 10 25 40 50 80 100	125 160 200 250 300	
Medium	Compressed air - filtered - lubricated		
Working pressure	0.5 - 10 bar		
Medium temperature	5 ° - 60 ° c		
Materials of construction	Aluminium, Brass, Nitrile, Polyurethane, Steel, Acetal		
Mountings	Front foot mounting Front flange	Rear flange	Double foot mounting Front trunnion Rear trunnion
Accessories	Clevis foot bracket Rod end fork		Trunnion bracket Rod end aligner

* For Non standard or longer stroke cylinders , contact your regional dealer or **JANATICS**

Output force (force in N: 1N = 0.1 kgf)

Bore dia in mm	Rod dia in mm		Working pressure in bar								
			2	3	4	5	6	7	8	9	10
12	6	Extend	20	30	40	50	60	70	80	90	100
		Retract	15	22	30	38	46	53	61	68	76
16	6	Extend	36	54	72	90	108	126	144	162	180
		Retract	31	46	62	78	94	108	124	140	156
20	8	Extend	56	84	112	140	169	196	224	254	282
		Retract	47	71	95	118	142	166	189	214	237
25	10	Extend	88	132	176	220	264	308	352	396	440
		Retract	74	111	148	185	222	260	296	334	371

(Above values have been worked out taking frictional loss into consideration)

AIR CYLINDER

Series A51, A52

Cat No A51 - 03

Basic cylinder

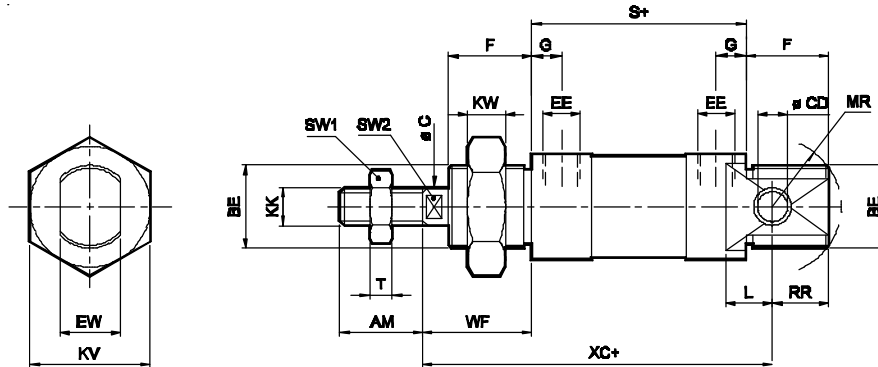

+ Add stroke

Bore Dia	MR	BE	F	CD H9	RR	L	G	EE	S	KW	C	SW1	SW2	KK	AM	T	WF ±1.2	XC ±1	EW d13	KV	Stroke tol		
																					10	100	125 - 300
12	17	M16 X 1.5	17	6	15	9	6	M5 X 0.8	51 ^{±0.5}	8	6	10	5	M6 X 1	16	3	22	75	12	24			
16	17	M16 X 1.5	17	6	15	9	6	M5 X 0.8	58 ^{±0.5}	8	6	10	5	M6 X 1	16	3	22	82	12	24	+ 1.5	+ 2.5	
20	20	M22 X 1.5	20	8	16	12	8	G 1/8	67 ^{±0.7}	10	8	13	7	M8 X 1.25	20	4	24	95	16	32	+ 0	+ 0	
25	21	M22 X 1.5	22	8	17	12	8	G 1/8	71 ^{±0.7}	10	10	17	9	M10 X 1.25	22	5	28	104	16	32			

MOUNTINGS FOR AIR CYLINDER Series A51

Front Foot Mounting

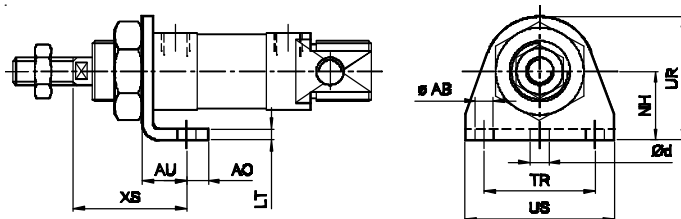

Bore dia	LT	AU	AO	d*	XS ±1.4	NH ±0.3	TR Js14	US	AB H13	UR
12	2	12	6	4.8	32	20	32	42	5.5	33
16	2	12	6	4.8	32	20	32	42	5.5	33
20	4	16	8	5.8	36	25	40	54	6.6	45
25	4	16	8	5.8	40	25	40	54	6.6	45

* Suitable for reaming

Double Foot Mounting

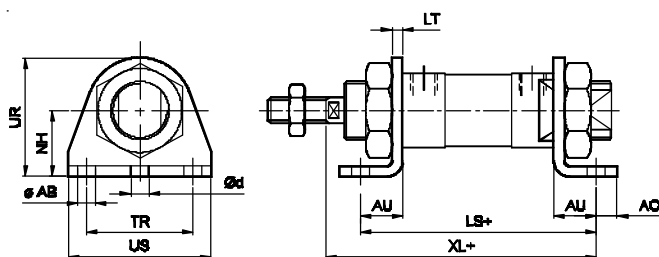

+ Add stroke

Bore Dia	UR	AB H13	TR Js 14	NH ±0.3	AO	AU	d*	LT	US	LS	XL ±1
12	33	5.5	32	20	6	12	4.8	2	42	75 ^{±0.7}	85
16	33	5.5	32	20	6	12	4.8	2	42	82 ^{±0.7}	92
20	45	6.6	40	25	8	16	5.8	4	54	99 ^{±0.9}	107
25	45	6.6	40	25	8	16	5.8	4	54	103 ^{±0.9}	115

* Suitable for reaming

Front flange

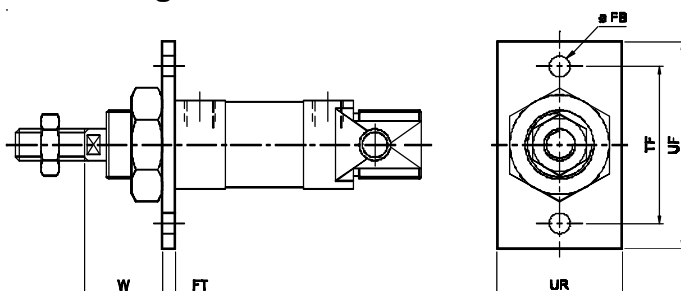

Bore dia	TF Js14	UF	UR	FB H13	FT	W ±1.4
12	40	50	30	5.5	4	18
16	40	50	30	5.5	4	18
20	50	66	40	6.6	5	19
25	50	66	40	6.6	5	23

AIR CYLINDER

Series A51, A52

Cat No A51 - 03

MOUNTINGS (continued)

Rear flange

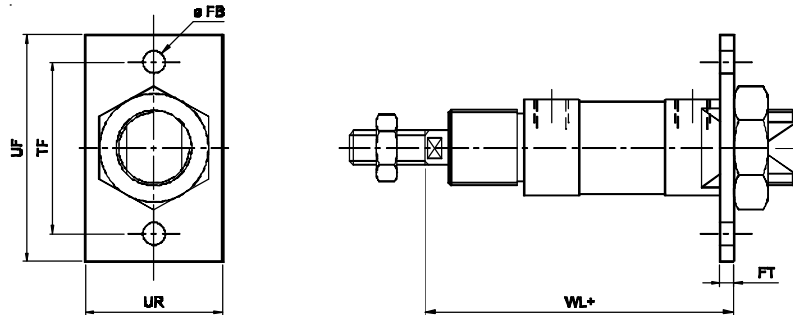

+ Add stroke

Bore dia	TF Js14	UF	UR	FB H13	FT	WL ±1.2
12	40	50	30	5.5	4	77
16	40	50	30	5.5	4	84
20	50	66	40	6.6	5	96
25	50	66	40	6.6	5	104

Front trunnion

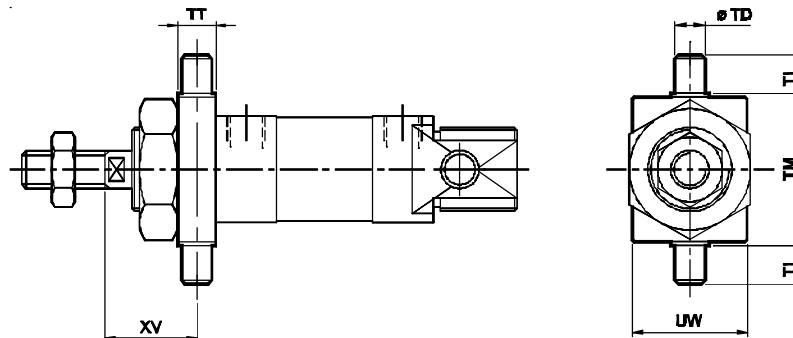

Bore dia	TM h14	UW	TD e9	TT	XV ±1.4	TL h14
12	30	25	6	8	18	10
16	30	25	6	8	18	10
20	40	30	8	10	19	10
25	40	30	8	10	23	10

Rear trunnion

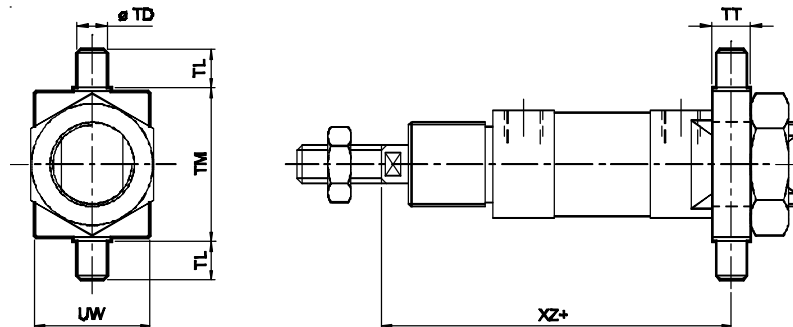

+ Add stroke

Bore dia	TM h14	UW	TD e9	TT	XZ ±1.2	TL h14
12	30	25	6	8	77	10
16	30	25	6	8	84	10
20	40	30	8	10	96	10
25	40	30	8	10	104	10

For trunnion brackets see " Accessories "

ACCESSORIES FOR AIR CYLINDER Series A51

Trunnion bracket

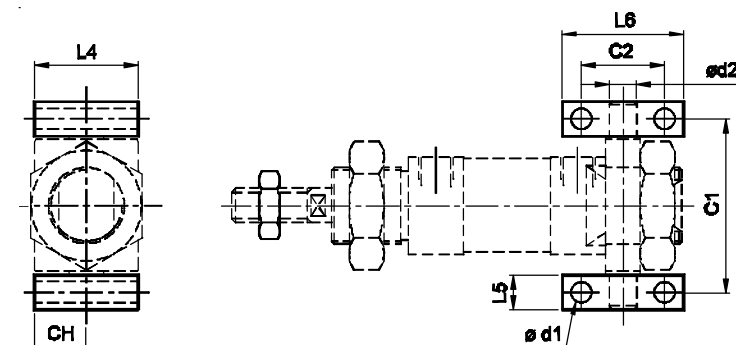

Bore dia	C1	C2 Js14	d1 H13	L4	L5	L6	CH	d2 H9	Ordering no.
12	38	20	4.3	25	8	30	16	6	AT016
16	38	20	4.3	25	8	30	16	6	AT016
20	50	24	6.6	30	10	35	20	8	AT022
25	50	24	6.6	30	10	35	20	8	AT022

AIR CYLINDER

Series A51, A52

Cat No A51 - 03

ACCESSORIES (continued)

Clevis foot bracket (CETOP - RP 107 P)

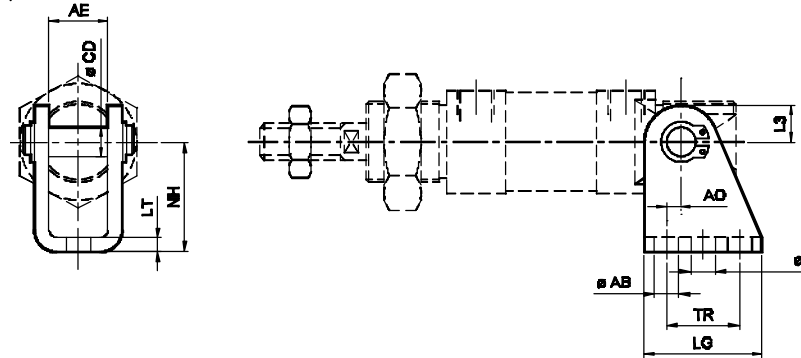

Bore dia	AE	AB H13	LT	NH	L3	CD e8	* d	TR Js14	LG	AO	Ordering no.
12	12.1	5.5	2	27	7	6	3.8	15	25	2	AA016
16	12.1	5.5	2	27	7	6	3.8	15	25	2	AA016
20	16.1	6.6	4	30	10	8	4.8	20	32	4	AA022
25	16.1	6.6	4	30	10	8	4.8	20	32	4	AA022

* Suitable for reaming

Rod end Fork (ISO 8140)

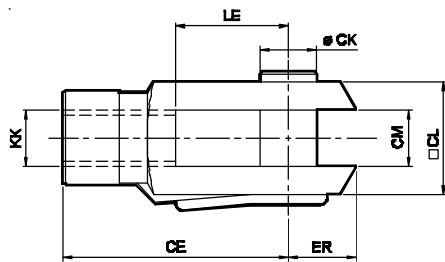

Bore dia	KK	LE	CM B12	CE	CK f8	CL	ER	Ordering no.
12	M6X1	12	6	24	6	12	9.5	AF006
16	M6X1	12	6	24	6	12	9.5	AF006
20	M8X1.25	16	8	32	8	16	13	AF008
25	M10X1.25	20	10	40	10	20	16	AF010

Rod end Aligner

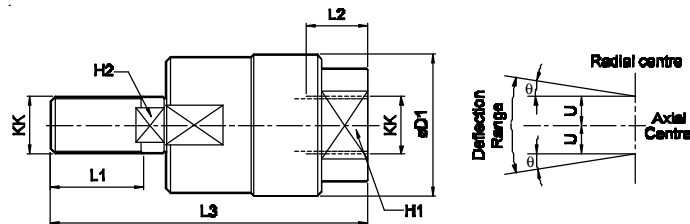

Bore dia	KK	L1	L2	L3	D1	H1	H2 ±9°	U	Ordering no.
12 / 16	M6X1	12	8	38	18	10	4 5	0.75	AR006
20	M8X1.25	15	10	48	20	12	7 5	0.75	AR008
25	M10X1.25	20	14	65	28	17	8 5	0.75	AR010

Rod end Spherical eye

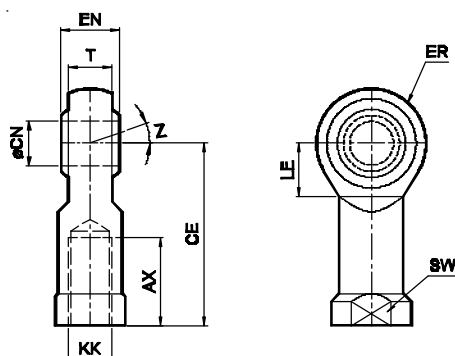

Bore dia	KK	CN H9	T	EN h12	CE min	LE max	ER	AX h13	SW	Z	Ordering no.
12 / 16	M6X1	6	6.75	9	30	11	10	12	11		AP006
20	M8X1.25	8	9	12	36	13	12	16	14	13°	AP008
25	M10X1.25	10	10.5	14	43	15	14	20	17		AP010

AIR CYLINDER

Series A51, A52

Cat No A51 - 03

ACCESSORIES FOR MAGNETIC CYLINDERS Series A52

REED SWITCH

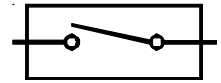

Function

The reed switch and clamping kit assembly is mounted on the Air cylinder (Series A52), for proximity sensing. The piston of the cylinder is equipped with a permanent magnet which activates the reed switch on approaching it. The reed switch closes the circuit giving an electrical signal, which could be used further as required. The accuracy of the sensing distance depends on the speed of operation of the piston.

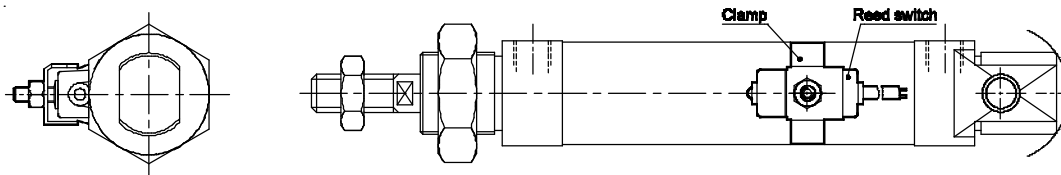

Technical Specifications - Reed Switch

Model	880006
Operating voltage	DC / AC 4 – 240V
Switching current	5 – 40mA
Contact rating	6(3)* W, 8(4)* VA
Voltage drop	2.5V max.
Response time	On + off <1ms
Switching logic	Normally open
Operating temperature	5° - 60° C
Type of protection	IP67
Colour of LED	Green
Cable	Ø 4, 2C

* when load is inductive

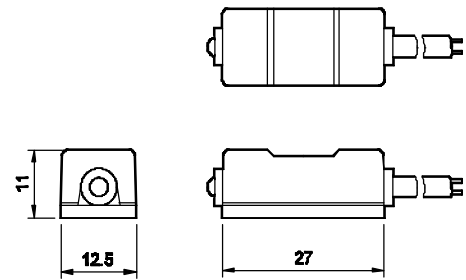

Bore Dia	X	Ordering no. for Clamp (a)	Ordering no. for Reed Switch (b)	Ordering no. (a+b)
12	32	810000	880006	AM1012
16	34	810001		AM1016
20	36	810002		AM1020
25	38	810003		AM1025

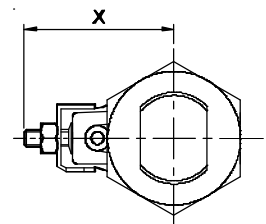

External protect circuit

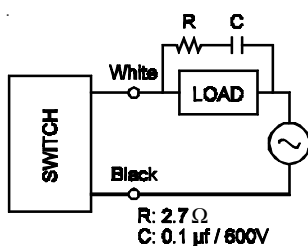
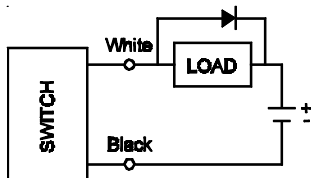

Circuit & connect diagram

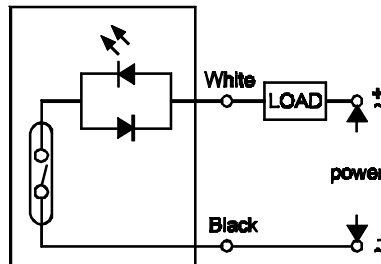

AIR CYLINDER

Series A51, A52

Cat No A51 - 03

How to order

A



Model	
51	Standard cylinder
52	Magnetic cylinder



Bore Ø (mm)	
012	- Ø 12
016	- Ø 16
020	- Ø 20
025	- Ø 25



Stroke (mm)	
010	- 10
025	- 25
040	- 40
050	- 50
080	- 80
100	- 100
125	- 125
160	- 160
200	- 200
250	- 250
300	- 300



Mountings	
O	- Basic
L	- Front Foot Mounting
D	- Double Foot Mounting
F	- Front Flange
R	- Rear Flange
M	- Front Trunnion
N	- Rear Trunnion

Example:

Ordering no. for standard cylinder with 16 dia bore, 50 mm stroke with Double foot mounting: A51 016 050 D



Note:

If ordered as 16 dia, 50 mm stroke cylinder, Basic cylinder A51 016 050 O will be supplied.

For repeat order when the details are taken from cylinder nameplate, mention the mounting style separately.

For ordering **Accessories**: mention part numbers in corresponding tables.

For ordering individual **Mounting** kits (If needed separately): mention the ordering numbers as below

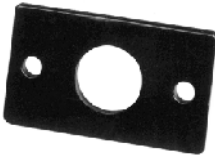
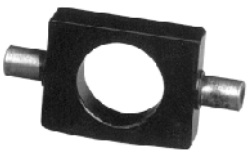
Bore dia	Front Foot mounting	Double Foot mounting	Flange (Front or Rear)	Trunnion (Front or Rear)
				
12	ML016	MS016	MF016	MT016
16	ML016	MS016	MF016	MT016
20	ML022	MS022	MF022	MT022
25	ML022	MS022	MF022	MT022

For your special requirements of cylinders or for further informations contact your regional dealer or **JANATICS**