

AIR CYLINDER

Series A10, A15

Cat No A10, A15 - 01 - 01

AIR CYLINDERS Double Acting (Ø 200) mm

Features

- ❑ Adjustable cushioning at both ends.
- ❑ Wide varieties of mountings.
- ❑ Low friction.
- ❑ Long life.

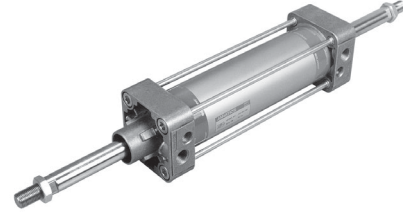

Technical Specifications

Cylinder bore Ø (mm)	200
Cushion length (mm)	40
Standard strokes* (mm)	50 80 100 125 160 200 250 300 320 400 500
Medium	Compressed air – filtered – lubricated
Working pressure	0.5 - 10 bar
Medium temperature	5 ° - 60 ° c
Materials of construction	Aluminium, Brass, Nitrile, Polyurethane, Steel, Acetal
Mountings	Basic cylinder, Foot mounting, Flange, Female clevis, Centre trunnion
Accessories	Trunnion bracket, Rod end fork, Rod end spherical eye

* For Non standard or longer stroke cylinders , contact your regional dealer or **JANATICS**

Output force (force in N: 1N = 0.1 kgf)

Bore Ø in mm	Rod Ø in mm	Working pressure in bar								
		2	3	4	5	6	7	8	9	10
200	40	5428	8143	10857	13571	16286	19000	21714	24429	27143

(Above values have been worked out taking frictional loss into consideration)

Basic cylinder

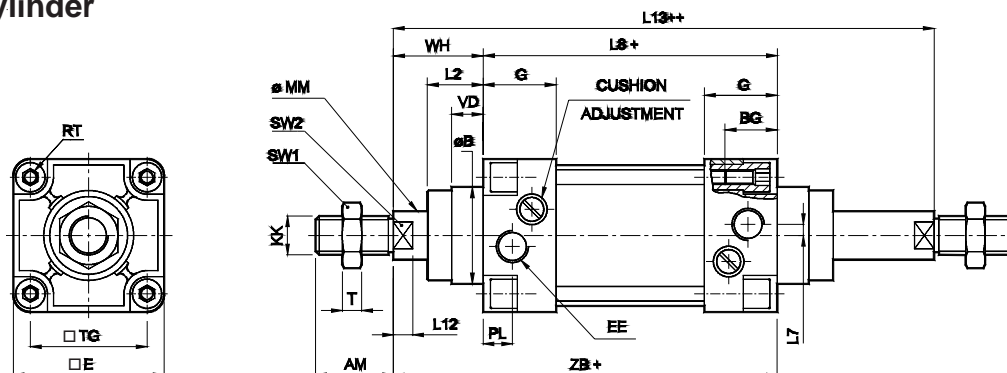

+ Add stroke
++ Add stroke twice

Bore dia	KK	AM	MM	SW2	L12	SW1	T	B e11	VD	L2	E max	G	TG	RT	BG min	EE	PL	L7	WH	tol	ZB	tol	L13	tol	L8	tol	Stroke tol
200	M36 x 2	72	40	36	16	55	14	75	8	70	222	51	175	M16	24	G3/4	26	15	95	±2.2	275	±1.5	372	±2	180	±1.3	+4 0

MOUNTINGS FOR AIR CYLINDER Series A10, A15

Foot mounting

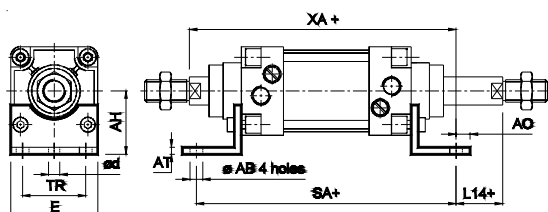

+ Add stroke

Bore dia	TR ±0.3	AB H13	AH Js15	AO max.	AT	E	d*	SA	tol	L14	tol	XA	tol	Recommended Bolt size
200	135	24	135	30	12	220	11.8	320	±2	27	±2.5	345	±2	M20

* Suitable for reaming

AIR CYLINDER

Series A10, A15

Cat No A10, A15 - 01 - 01

Flange

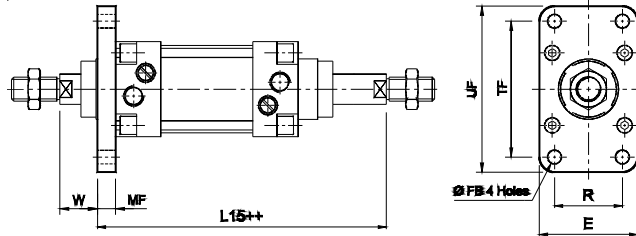

++ Add stroke twice

Bore dia	TF ± 0.3	R ± 0.3	FB H13	MF	UF	E	W	tol	L15	tol	Recommended Bolt size
200	270	135	22	25	321	221	70	± 2.5	302	± 2.5	M20

Female clevis

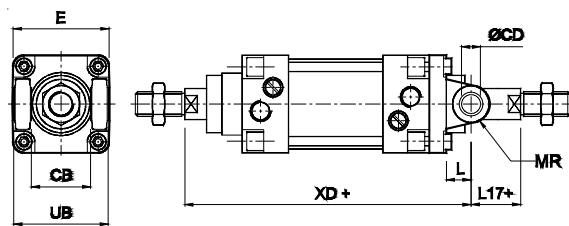

+ Add stroke

Bore dia	CD H9	CB H14	L	MR	UB h14	E max.	L17	tol	XD	tol
200	30	90	35	31	170	220	37	± 2.5	335	± 1.8

Centre trunnion

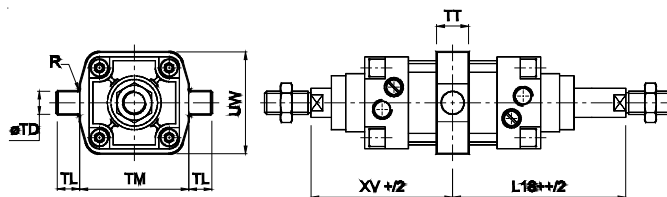

+ Add stroke
++ Add stroke twice

Bore dia	TD e9	TL h14	TM h14	UW	TT	R	XV	tol	L18	tol
200	32	32	250	248	49	2.5	185	± 2.5	187	± 2.5

ACCESSORIES FOR AIR CYLINDER Series A10, A15

Trunnion bracket

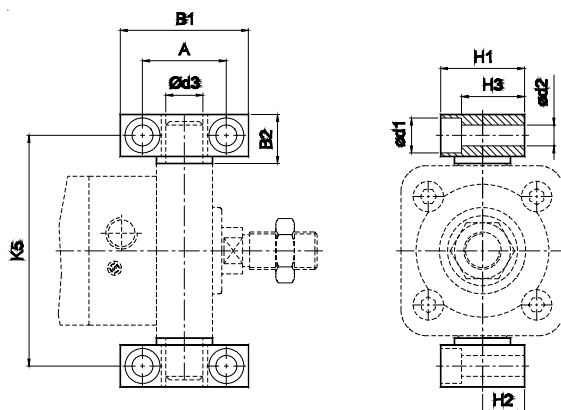

Cylinder bore \varnothing	B1	B2	A ± 0.2	d1	d2 H13	d3 H9	H1	H2 ± 0.1	H3	K5 Js14	Ordering no.
200	92	40	60	25	18	32	60	30	43	295	AT0160

Rod end Fork (ISO 8140)

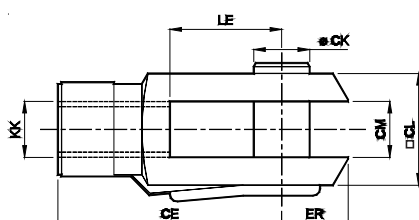

Cylinder bore \varnothing	KK	CE	CK f 8	CM B 12	LE	ER max.	CL	Ordering no.
200	M36 x 2	144	35	35	72	53	70	AF035

AIR CYLINDER

Series A10, A15

Cat No A10, A15 - 01 - 01

Rod end spherical eye (ISO 8139)

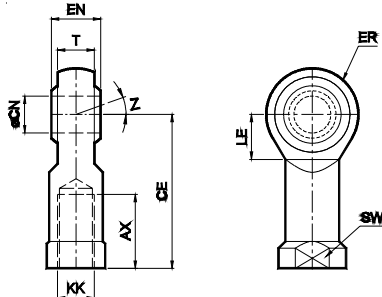

Cylinder bore Ø	KK	CN H9	T	EN h12	CE	LE min	ER max	AX	SW	Z	Ordering no.
200	M36 x 2	35	28	43	125	41	40	56	50	15°	AP036

How to order

A

Model		Cylinder bore (mm)		Stroke (mm)		Mountings	
10	Magnetic cylinder	200	- Ø 200	050	- 50	O	- Basic
15	Standard cylinder			080	- 80	L	- Foot Mounting
				100	- 100	F	- Flange
				125	- 125	B	- Female Clevis
				160	- 160	T	- Center Trunnion
				200	- 200		
				250	- 250		
				300	- 300		
				320	- 320		
				400	- 400		
				500	- 500		

(For details of accessories for magnetic cylinders refer Cat No A12, A13 - 01 - 01)

Example:

Ordering no. for magnetic cylinder with 40 dia bore, 50 mm stroke with female clevis mounting: **A10 200 050 B**

Note:

If ordered as 40 dia, 50 mm stroke cylinder, Basic cylinder **A11 200 050 O** will be supplied.

For repeat order when the details are taken from cylinder nameplate, mention the mounting style separately.

For ordering **Accessories** refer corresponding tables for part numbers.

For ordering individual **Mounting** kits (If needed separately) the order numbers are as below

Cylinder bore Ø	Foot mounting	Flange	Female clevis
200	ML0200	MF0200	MB0200

For your special requirements of cylinders or for further informations contact your regional dealer or **JANATICS**

Subject to change