

AUTO DRAIN VALVE

Series NA1

Cat No APA - 01

AUTO DRAIN VALVE suitable for Filter Series F13, F14, F15 and Filter Regulator combination series FRC13, FRC14 and FRC15

Features

- ❑ Individual unit (Externally mountable)
- ❑ Low operating pressure
- ❑ Compact size
- ❑ Elegant design and finish
- ❑ Long life

Function

These Auto drain units are externally mountable on G1/4, 3/8 and 1/2 size Filters and FRC units.

As the condensed water collects in the drain unit, the float moves up and drains the water.

The condensate water can also be drained manually.

A plastic tube can be fitted at the bottom of the auto drain unit to take the drained water away from the unit.



Technical Specifications

Ordering No.	A2D01	A2D02	A2D03
Size	1 / 4	3 / 8	1 / 2
Medium	Compressed air		
Operating pressure (bar)	2 – 10 bar		
Ambient Temperature	0 - 60°C		
Installation	Vertical (as in the picture)		
Materials of construction	Aluminium, Brass, Acetal, Stainless steel, Nitrile		

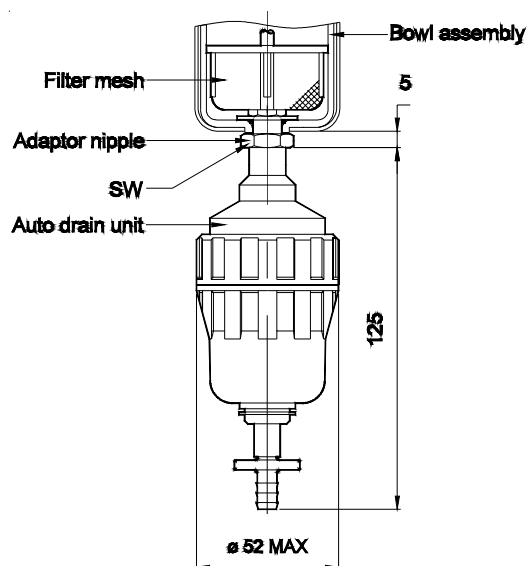

Size	SW	Ordering no.
G1/4	19	A2D01
G3/8	19	A2D02
G1/2	22	A2D03



Note

When ordered as A2D01, auto drain unit with a adaptor kit and a filter mesh for G1/4 Filter or FRC will be supplied.

Subject to change