

# EXTINGUISHER BOX (SINGLE)

## MILD STEEL



Extinguisher boxes provide the means to store portable extinguishers safely in indoor and outdoor locations. They protect the Extinguisher and its contents from the effects of weather, dust, etc, and allow quick deployment of the same in the event of emergency. Extinguisher Boxes can be mounted on the wall, or if outdoors, on specially fabricated stands.

**Brief Description :** AAAG Extinguisher Box, Single, made of Carbon (Mild) Steel sheet, 18 gauge thickness, suitable for storage of 1 No. portable Extinguisher (DCP- 9/10 kgs capacity or CO<sub>2</sub> – 4.5/5 kgs capacity). Box shall have glass front, and locking arrangement (& small glass window for storing key opener).

### 1.0 GENERAL DATA

1.1	Make	AAAG
1.2	Size/ Model	Extinguisher Box (Single)
1.3	Material of Construction	Carbon (Mild) Steel
1.4	Reference	--

### 2.0 MATERIAL OF CONSTRUCTION

2.1	Body	Mild Steel SWG 18 Gauge
2.2	Handle	Nickel Chrome
2.3	Key Box	Mild Steel SWG 18 Gauge
2.4	Lock	Standard Panel Lock / Godrej

### 3.0 TESTING AND QUALITY CONTROL

3.1	Dimensional check	See Drawing Below
3.2	Documentation	Internal inspection report, supplier's certificates, approved laboratory test certificates

### 4.0 OPERATIONAL/ TECHNICAL DATA

4.1	Dimensions	As per Extinguisher Size/capacity
4.2	Weight (Approx.)	---

### 5.0 FINISH

5.1	Branch	2 Coats Anticorrosive Fire Red Paint Outside, and White Inside
-----	--------	--

### 6.0 APPROVALS & MARKING

6.1	Approvals	--
6.2	Marking on Nozzle	AAAG/ Year of Mfg

### 7.0 WARRANTY

7.1	Warranty & Guarantee	12 Months from the date of supply
-----	----------------------	-----------------------------------

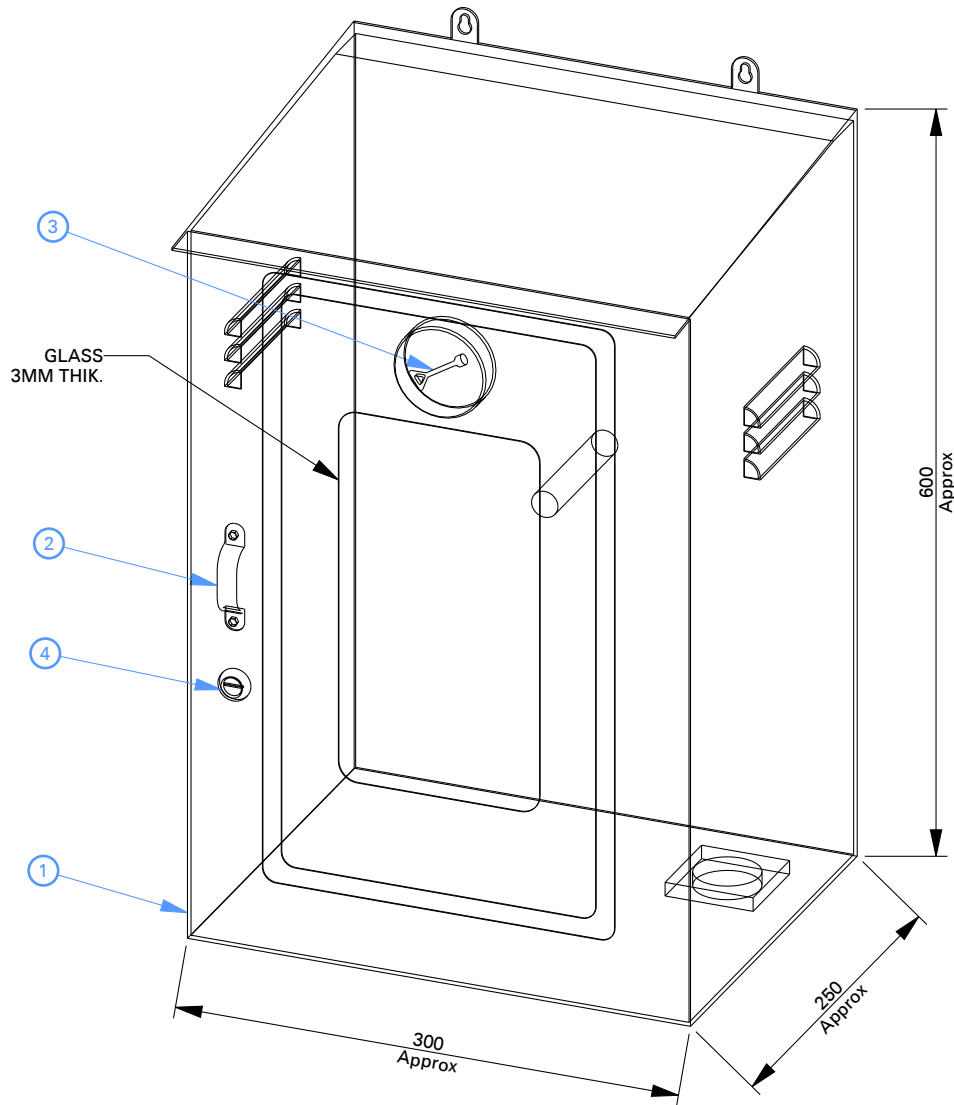

1	Body	C.S 18 SWG
2	Handle	Chrome Plated
3	Key	M.S Galvanized
4	Lock	Pannel Lock
NO	DESCRIPTION	MATERIAL
PART LIST		



**Shah Bhogilal Jethalal & Bros.**

AHMEDABAD

**TITLE :**

Extinguisher Box, Single,  
Carbon Steel, Conventional Design

**SCALE**

N.T.S

**DRAWING NO:**

M253-00BJ

**SHEET**

1 OF 1

**REV.**

0