

EH26NW, Hi - Speed Hand Dryer

TECHNICAL DATA

TECHNICAL SPECIFICATIONS

- Construction: Stainless Steel (#304, Non Magentic)
- Mounting: Wall mounted
- Operation: Touch-Free Infra-Red activation
- Hand Dry Time: Less than 20 seconds
- Auto Cutoff: 60 Seconds
- Motor: Brush AC type
- Motor Speed: 25000 RPM

Voltage: 220V/50Hz

- Rated Power: Motor 550 W
- Current: 15A
- Water Splash: IPx1
- Air Speed: 95 m/s
- Sensing Range: 12 - 15 cm

FEATURES

- Costs Effective - Compared to paper towels, the Euronics Hand Dryer costs 95% less to operate and represents 83% less impact on our environment.
- Carbon Footprint - The best Hand Drying alternative for environment with 70% smaller carbon footprint than Paper Towels
- Euronics Hand Dryer dries 8 PAIR OF HANDS in the cost of 1 Paper Towel
- Cleanliness - Where paper towels dispensers contribute to waste paper thrown on the floor, the Euronics Jet Hand Dryer keeps a clean and sanitary environment at all times.
- Labor Cost - Further expenses related to paper towels include having employees fill dispensers, pick up litter, empty trash bins.
- Save Tree - It takes about 17 trees to produce a ton of paper. The environmental impact of this would include the effects of logging and paper mills on wildlife habitat, energy use, global warming, and air pollution.

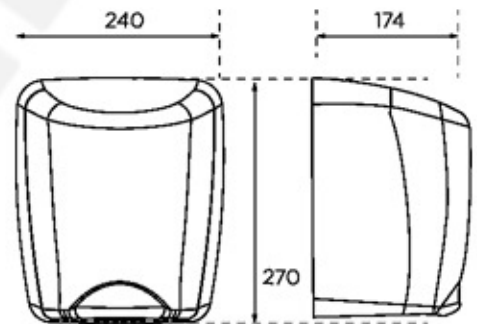

(Dimensions in mm)

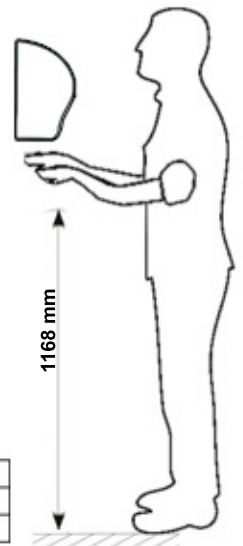

RECOMMENDED MOUNTING HEIGHTS

From floor level

Men	Ladies	Disabled
46"	44"	40"
1168mm	1117mm	1016mm

Euronics