



Hydropneumatic Pumping System

System Description

Xylem's **Hydropneumatic Pumping System** is supplied as a complete set including suction and discharge common manifolds, non-return valves, isolating valves, pressure transmitter, and pressure gauge of suitable range on the discharge side, float switch for the suction tank and control

panel inclusive of dedicated pumping controller (CONSYS), variable frequency drive, circuit breakers, fuses and other necessary electrical components for Manual and Auto operation.
(Optional: Suitably sized Pressure Tanks)

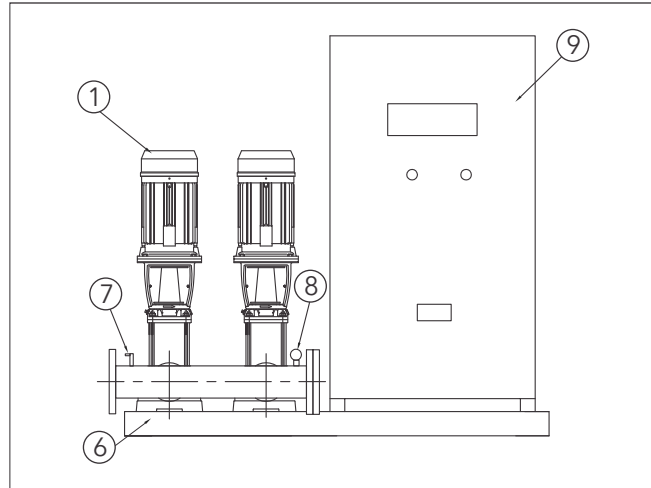
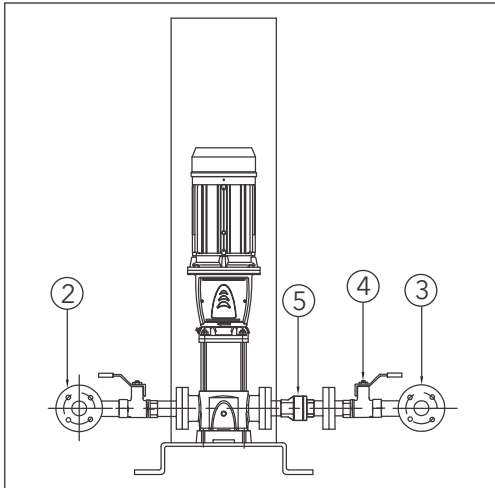

Specifications

Pos.	Description	Quantity (Nos.)
1	Pump set	2 - 6
2	Suction Manifold (Galvanized MS)*	1
3	Discharge Manifold (Galvanized MS)*	1
4	Isolating Valve	2 per pump
5	Non - return valve	1 per pump
6	Base frame (MS epoxy painted)	1
7	Pressure transmitter	1
8	Pressure Gauge	1
9	Control Panel (Inclusive of controller & VFD)	1

*Refer factory for optional material

System operation

Receiving sensor inputs, staging / destaging of pumps, controlling VFD speed and monitoring the motor performance to meet system demands are overall functions of the pump controller (CONSYS). The controller combines PID functions, set point modifications and system component status into a single, central, user friendly control cabinet.

When demand occurs, the controller senses the pressure drop in the delivery line through pressure transmitter. Initial water demand is met by pre-charged pressure vessel. Should the water demand continue the system pressure will dip to a preset pump cut - in point and controller starts the first pump on VFD. The pump set gradually speed up to achieve the set pressure. Controller will continuously scan and compare actual pressure with the set pressure and speed of the lead pump varies according to requirement. When demand increases, pressure in the

system will drop further. Speed of the lead pump will increase to its maximum, then lag pump(s) will be called on after a time delay and will operate in parallel with lead pump to try and maintain the set pressure.

At peak demand all the pumps operate, similarly if there is a drop in water demand the duty pump speed starts to reduce, then lag pumps cuts-off, followed by stopping of the duty pump.

Pressure vessel is connected on discharge side to take care of small requirements. It also reduces the number of Start / Stop of pumps and reduces water hammering in the delivery line.

The pumping system maintains a constant pressure regardless of the system demand.

CONSYS Controller Features



HMI mounted on panel door and processing unit mounted inside the control panel

HMI is for monitoring the unit and processing unit is for functioning the system. The controller is microprocessor based with 20 characters 4 lines display for clear vision and NEMA 1 enclosures. The controller is equipped with inbuilt PID and real time clock function. The controller is compatible to run on 50 Hz and 60 Hz supply voltage. The controller is CE marked, UL listed and CSA certified.

Automatic control up to 6 pumps in parallel

The controller is programmed to handle up to 6 pumps with automatic staging and destaging of pumps based on demand to maintain a constant pressure in the delivery line irrespective of consumption.

Set point

The desired pressure is adjustable through HMI. Separate 'set points' can be programmed through HMI and switching between set points is timed by a real time clock.

Stand by pumps

The system operation is selectable with and without standby pumps.

Data login

- Last 100 alarms with date and time
- Individual pump run hour

Alarm

The alarm menu displays all faults that occurred during the operation, logging the time and date of when the fault occurred. Last 100 alarms can be logged as history in the controller.

Building Management services

Serial communication through MODBUS RTU (RS 485) protocol to interact with Building central control and monitoring.

Variable Frequency Drive

Variable frequency drive is of Pulse Width Modulation type with inbuilt RFI and harmonic dampers.

Control Panel

An IP 54 / IP 55 powder coated steel enclosure house all the electrical components inclusive of VFD and controller. The panel is built to start the pumps in suitable starting methods. Up to 5.5 KW DOL methods, 7.5 and above Star / Delta method is used to start the pumps. The control panel is equipped with necessary circuit breakers and isolators.

Assembly and Testing

The system is completely assembled at Xylem India factory at Vadodara. The system is fully tested, hydraulically and electrically prior to dispatch.

Application

Building Sector (Residential Complex, Multistoried Buildings, Hotels, Hospitals, IT Parks Commercial Complex, Corporate Offices, etc.)
Pressurized Water Distribution - Utility and Flushing
Landscaping

Municipal Corporation Water Supply
Water Supply to elevated areas
Water Treatment Plant

Irrigation
Drip & Sprinkler Systems
Automation of water supply for Green Houses / Nurseries

Automobile Sector
Components Washing

Industrial
Textile, Breweries, Dairy, Food, Distilleries, Cooling Tower, Spray Ponds



Xylem Water Solutions India Pvt. Ltd.

India Head Office
Ground & First floor
Vishnu Shivam Mall
Thakur Village, Kandivali [East]
Mumbai- 400 101
Tel: +91 22 4037 0370
Fax: +91 22 4037 0371

Registered Office & Factory
Plot No.731, GIDC Savli
Manjusar, Savli Road
Vadodara - 391770
Tel: +91 2667 265800
Fax: +91 2667 265802

Delhi Office
H-20, Bali Nagar
New Delhi - 110015
Tel: +91 11 4555 2806
Fax: +91 11 2519 5007

Bengaluru Office
No. 7, Kumara Park East
Kumara Park East Extension
Bengaluru - 560001
Tel: +91 80 4281 6800
Fax: +91 80 4281 6801

www.xyleminc.com/www.xylemindia.in

Chennai Office
Ghatala Towers, 1st floor
19, Avenue Road
Nungambakkam
Chennai - 600034
Tel: +91 44 4043 5555
Fax: +91 44 4043 5550



Email: indiasales@xyleminc.com, indiaservice@xyleminc.com