

Wet/Wet Differential Pressure Transmitter

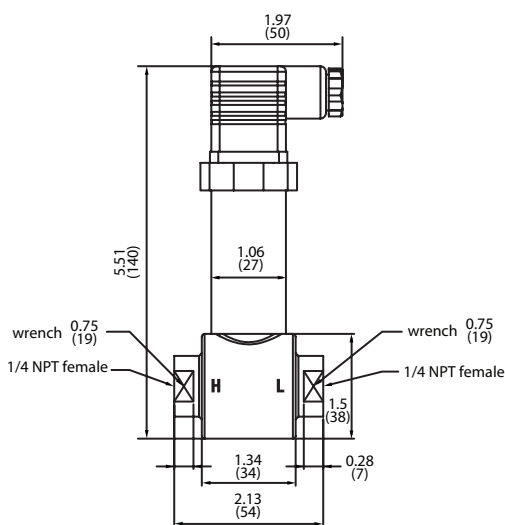

DIMENSIONS



SPECIFICATIONS

Media Compatibility: Gas and Liquids compatible with 316SS

Accuracy: +/- 0.25% F.S.

Over Pressure: positive - 2x F.S.; negative - 1x F.S.

Working Pressure: 1000 PSI (7MPa)

Temperature Limits:

Operating: -40° to 185° F (-40° to 85° C)

Compensated: -4° to 158° F (-20° to 70° C)

Thermal Effect: 0.028%/° F (0.050%/° C)

Stability: 0.5% F.S./yr

Power Supply: 12-36 VDC

Output Signal: 4-20 mA, 2 wire

Electrical Connection: mini DIN 43650

Response Time: 100 ms

Turn Down: 5:1

Enclosure Rating: NEMA 4X (IP 65)

Process Connection: 1/4" NPT female; optional 1/4" G

Mounting Position Effect: 0.1% F.S., can be corrected by zero adjust.

- 0.25% Accuracy
- 316 Stainless Steel Construction
- 1000 PSI Working Pressure
- 5:1 Turn Down
- Certificate of Calibration

The Series 251 wet/wet differential pressure transmitter utilizes a double diaphragm sensor technology that outperforms standard double sensor products in accuracy, reliability and static operating pressure. This differential pressure sensing technology offers 0.25% accuracy with static operating pressures up to 1000 PSI (7 MPa). The Series 251 features 316 stainless steel construction designed to meet NEMA 4X (IP 65) standards. The transmitter also offers exceptional field flexibility with a 5:1 turn down and comes standard with a certificate of calibration.

MODEL NUMBERS

Model	Range
251-01	0-5 PSI (34.5 kPa)
251-02	0-10 PSI (68.9 kPa)
251-03	0-15 PSI (103.4 kPa)
251-04	0-30 PSI (206.8 kPa)
251-05	0-50 PSI (344.7 kPa)
251-06	0-100 PSI (689.5 kPa)
251-07	0-150 PSI (1034 kPa)
251-08	0-300 PSI (2068 kPa)
251-09	0-500 PSI (3447 kPa)

Consult factory for other calibration ranges or process connections