



EMMOTION MODULES

114, 6th Cross, 3rd Main, BHCS Layout, Subramanyapura Post,
Uttarahalli, Bengaluru - 560061. Ph.: 080-26395978
Mobile : +91-96861 43312 E-mail : emechdrives@gmail.com

GENERAL SPECIFICATION

Stepper Motor Model	EMM 57S100-008
Step Angle	1.8 Degrees per step
Optimum motor Temperature	80 Degrees C Maximum
Operating Ambient Temperature	-20°C TO +50° C
Storage Temperature	-20°C TO +60°C
Operating Ambient Humidity	90% RH ,40' MAX (no condensation)
Insulation Resistance	100M OHM MIN,500V DC Megger at normal room temperature and humidity
Dielectric Strength	At normal room temperature and humidity motor can with stand 1500V AC applied between winding and motor body for 1 minute
Shaft Radial Play	0.02mm Mamimum (450 Gms – Load)
Shaft Axial Play	0.08mm Maximum (450Gms – Load)
Maximum Radial Force	75N (20mm From the flange)
Maximum Axial Force	15 N-M
Thermal Class	CLASS B (+130 Degree C)
Protection Grade	IP40
Mounting Direction	Can be mounted in both horizontal and vertical direction

ELECTRICAL SPECIFICATION

No of Phase	2 Pahse
Stepping Angle	1.8 Degrees per step
Voltage Per Phase	2.53 Volts
Current Per Phase	3.50 Amps
Resistance Per Phase	1.2 Ohms
Inductance Per Phase	4.00 m H
No of Leads	4 Wire

MECHANICAL SPECIFICATION

Holding Torque	30 Kg-Cm
Detent Torque	1000 Gm-Cm
Rotor Inertia	600 Gm-cm
Motor Mass	1.6 Kg

Unspecified tolerances
±.05mm

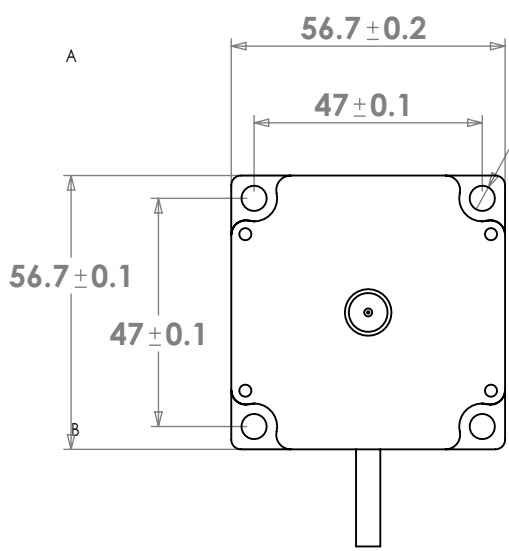

Ø 5.2 Holes-4 No's

4.5 mm Flat

Ø 38.1 ± 0.03

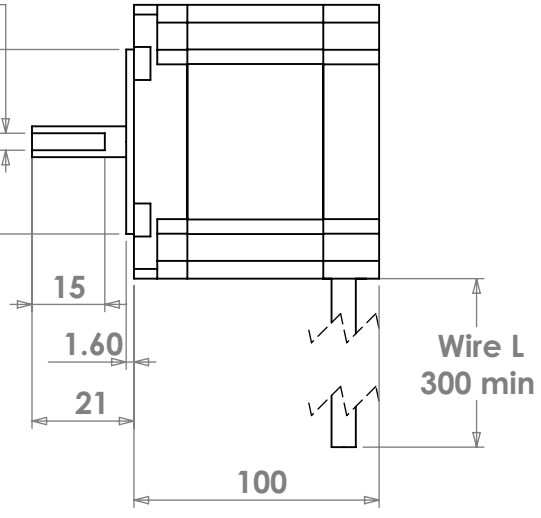

Ø 8 to -0.02

4.80

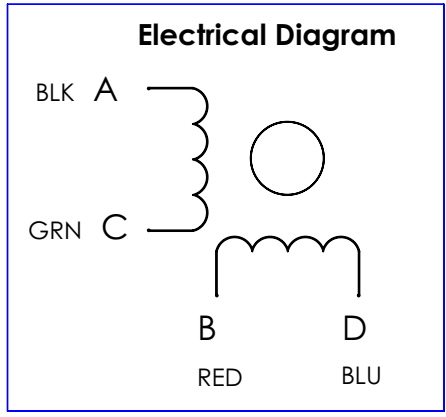
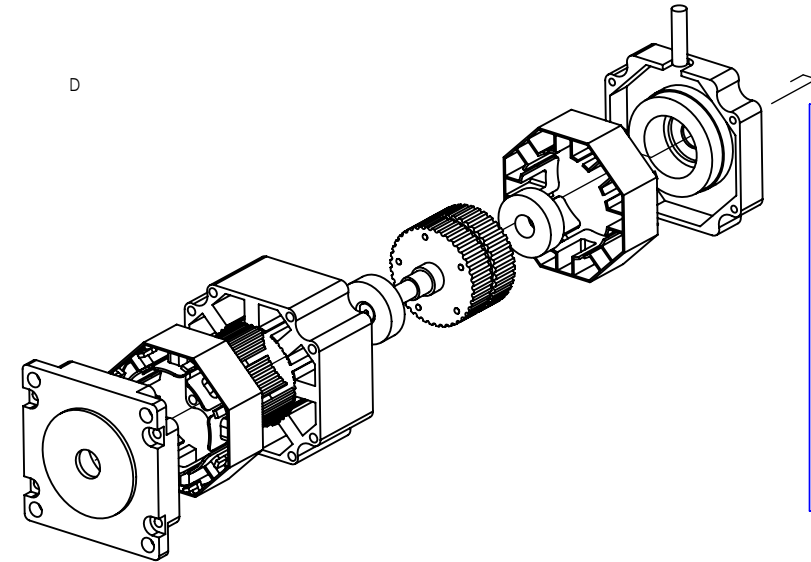
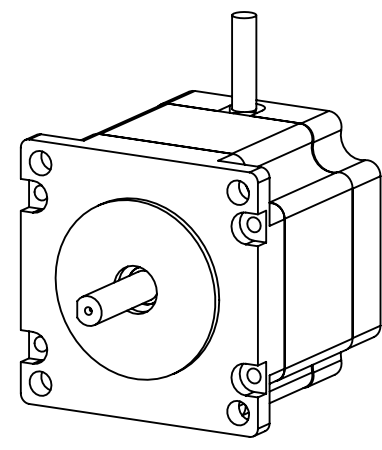
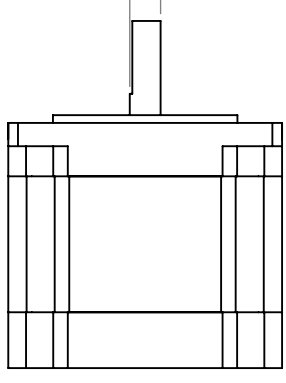

The information in this Drawing is the sole property of EM MOTION MODULES . Any reproduction of the part or a whole without written permission from EM MOTION MODULES is strictly prohibited.



EM MOTION MODULES

Part Name : NEMA-23

Drg No. :

Part No : EMM57S100-800

Revision status :

Assembly : 2 PHASE STEPPER MOTOR