

## AV-288 (CF8) C.S.S. Gate Valve, Class-150

### Features

Bolted Bonnet, O/S & Yoke Type, Rising Stem, Renewable Seat, Solid or Flexible Wedge, SS 304 Trim.

Flanges as per ASME B16.5, Class-150 RF (Drilled)

Product Standard: BS-1414/API-600

### Test Pressure

Body : 30 Bar (Hyd.)

Seat : 22 Bar (Hyd.)

Testing Standard : BSEN 12266-1/ API-598

### Suitability

Water, Steam, Oil



### Material Combination

P.No.	Name of Part	Material	Specification
1	Body	C.S.S	ASTM A351 Gr. CF8
2	Body Seat Ring	C.S.S/ F.S.S.	ASTM A351 Gr. CF8/ASTM A182 Gr. F304
3	Wedge	C.S.S	ASTM A351 Gr. CF8
4	Gasket	S.S. 304 Graphoil Filler With Inner Ring	-
5	Studs & Nuts	Alloy Steel/ H.T Steel	ASTM A193 Gr. B7/B8/ASTM A194 Gr. 2H/8
6	Bonnet	C.S.S	ASTM A351 Gr. CF8
7	Stem	Stainless Steel	ASTM A276 TYPE 304
8	Back Seat Bush	Stainless Steel	ASTM A276 TYPE 304
9	Gland Packing	Flexible Graphite	-
10	Gland Follower	Stainless Steel	ASTM A276 TYPE 304
11	Gland Flange	C.S.S.	ASTM A351 Gr. CF8
12	Gland Studs & Nuts	Alloy Steel/ H.T Steel	ASTM A193 Gr. B7/B8/ASTM A194 Gr. 2H/8
13	Yoke Sleeve	Al. Bronze	BSEN 1982 Gr. CC331G
14	Yoke sleeve Retaining Nut	C.S.S.	ASTM A351 Gr. CF8
15	Handwheel	M.I./ D.I.	ASTM A338/ASTM A536 Gr. 80-55-06
16	Handwheel Retaining Nut	C.S.S/S.S.	ASTM A351 Gr. CF8/ASTM A276 TYPE 304
17	Yoke*	C.S.S.	ASTM A351 Gr. CF8
18	Gear Box Assembly*	C.I.	-

NOTE : 1. Parts marked with \* are optional and are for particular sizes.

2. This item can be supplied in WC6, WC9 material also.

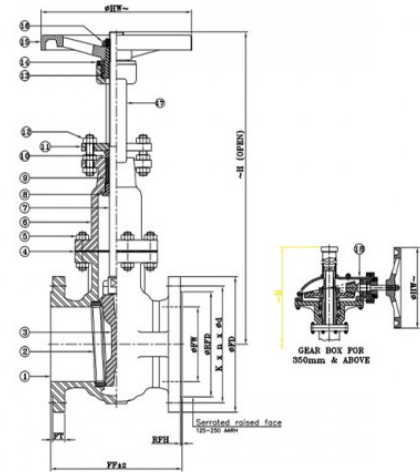

### Dimensional Data

Nominal Size (mm)	FF	FT	ØFW (Min.)	ØRFD	RFH	ØFD	k	n	Ød	ØHW	H
40	165 ±2	12.7	38.1	73	2	125	98.4	4	5/8"	210	320
50	178 ±2	14.3	50.8	92.1	2	150	120.7	4	3/4"	210	390
65	190 ±2	15.9	63.5	104.8	2	180	139.7	4	3/4"	210	440

Nominal Size (mm)	FF	FT	ØFW (Min.)	ØRFD	RFH	ØFD	k	n	Ød	ØHW	H
80	203 ±2	17.5	76.2	127	2	190	152.4	4	3/4"	225	460
100	229 ±2	22.3	101.6	157.2	2	230	190.5	8	3/4"	255	570
125	254 ±2	22.3	127	185.7	2	255	215.9	8	7/8"	310	690
150	267 ±2	23.9	152.4	215.9	2	280	241.3	8	7/8"	310	780
200	292 ±2	27	203.2	269.9	2	345	298.5	8	7/8"	400	975
250	330 ±2	28.6	254	323.8	2	405	362	12	1"	460	1215
300	356 ±3	30.2	304.8	381	2	485	431.8	12	1"	500	1350
350	381 ±3	33.4	336.6	412.8	2	535	476.3	12	1/1/8"	450	1605
400	406 ±3	35	387.4	469.9	2	595	539.8	16	1/1/8"	450	1960
450	432 ±3	38.1	436.2	533.4	2	635	577.9	16	1.1/4"	450	2055
500	457 ±3	41.3	489	584.2	2	700	635	20	1.1/4"	450	2410
600	508 ±3	46.1	590.6	692.2	2	815	749.3	20	1.3/8"	450	2875

k - P.C.D; n - Number of Holes; Ød - Diameter of Holes