

FV-505 Forged Brass Ball Valve, PN-25

Features

Two Piece Design, Lever Operated (Blow Out Proof Stem), Renewable Seat
Screwed Female BSP Parallel Threads (BS-21)

Test Pressure

Body - 550 Psi g (Hyd.)
Seat - 400 Psi g (Hyd.), 100 Psi g (Steam)

Suitability

Water, Gas, Oil, Air



Material Combination

P.No.	Name of Part	Material	Specification
1	Body Connector	Forged Brass	IS 6912 Gr FLB
2	Ball	Forged Brass	IS 6912 Gr FLB
3	Seat	PTFE	-
4	Gasket	PTFE	-
5	Packing Ring	PTFE	-
6	Gland	Brass	IS 6912 Gr. FLB / FHTB1
7	Lever	Carbon Steel	-
8	Locking Nut	Brass	IS 6912 Gr. FLB / FHTB1
9	Stem	Brass	IS 6912 Gr. FLB / FHTB1
10	Body	Forged Brass	IS 6912 Gr. FLB

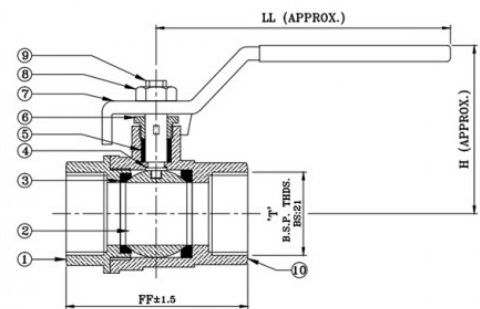

Dimensional Data

Nominal Size (mm)	FF ±1.5	LL	T	H
15	50	96	1/2"	54
20	58	102	3/4"	52
25	63	102	1"	54
32	80	168	1.1/4"	79
40	90	117	1.1/2"	82
50	103	157	2"	83
65	135	217	2.1/2"	125
80	150	225	3"	125
100	180	225	4"	150