

FV-501 Gun Metal Ball Valve, PN-20

Features

Two Piece Design, Full Bore, Lever Operated (Blow Out Proof Stem), Renewable Seat, SS Trim
Screwed Female BSP Parallel Threads (BS-21)

Test Pressure

Body - 500 Psi g (Hyd.)

Seat - 250 Psi g (Hyd.), 150 Psi g (Steam)

Suitability

Water, Steam, Oil, Air



Material Combination

P.No.	Name of Part	Material	Specification
1	Body	Gun Metal	BSEN 1982 Gr. CC491K
2	Seat	PTFE	-
3	Ball	Stainless Steel	AISI 304
4	Stem	Stainless Steel	AISI 304
5	Packing	PTFE	-
6	Gland	Gun Metal	BSEN 1982 Gr. CC491K
7	Lever	Carbon Steel (PVC Coated)	
8	Lever Nut	Stainless Steel	AISI 410
9	Body Connector	Gun Metal	BSEN 1982 Gr. CC491K

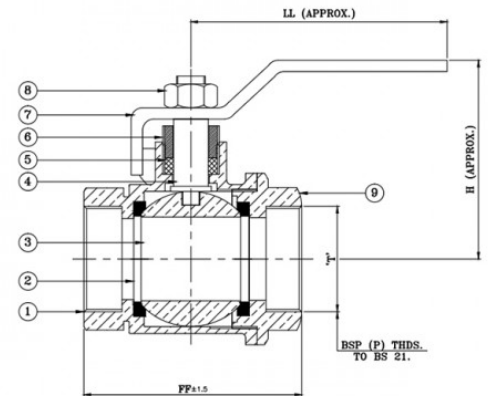

Dimensional Data

Nominal Size (mm)	FF ±1.5	H	LL	T
15	60	65	100	1/2"
20	68	65	115	3/4"
25	74	74	130	1"
32	86	87	150	1.1/4"
40	98	105	175	1.1/2"
50	118	110	205	2"
65	146	160	325	2.1/2"
80	159	190	380	3"
100	202	205	380	4"