

FIBERGLASS LADDERS



Company Profile :

Sumip Composites Pvt. Ltd. is known for the quality performance of its fiberglass products be it ladders, cable trays, canopies, street light poles, luminaires etc. It is a company promoted by a group manufacturing industrial electrical products for last three decades, specially designed for the use in critical environment. Fiberglass products were specifically developed due to demand from the valued wide client base.

We make safe ladders :

All our ladders are designed and made to meet the applicable standards & requirements of the National (IS) as well as International standards like American National Standards Institute (ANSI), OSHA etc.



OSHA has set minimum requirement with respect to the use of ladders in business and industry.

All ladders must be constructed in compliance with applicable safety codes of the American National Standards Institute (ANSI).



Variety of ANSI safety codes are available depending on material and type of ladders. The applicable ANSI codes are as follows.

WOOD LADDER	ANSI A14.1
METAL LADDER	ANSI A14.2
FIXED LADDER	ANSI A14.3
FIBERGLASS LADDER	ANSI A14.5
STEEL LADDER	ANSI A14.7
STAGE PLATFORM	ANSI A10.8
ROLLING SCAFFOLD	ANSI A10.8

In addition, ANSI codes have established a Duty Rating which identifies the use for which a portable ladder is intended and the conditions under which the ladder can be used safely. The following table describes the various types of ladders.

TYPE	CAPABLE OF SUPPORTING	RATED USE
TYPE IAA	375Lbs.	EXTRA HEAVY DUTY INDUSTRIAL
TYPE IA	300Lbs.	EXTRA HEAVY DUTY INDUSTRIAL
TYPE I	250Lbs.	HEAVY DUTY INDUSTRIAL
TYPE II	225Lbs.	MEDIUM DUTY COMMERCIAL
TYPE III	200Lbs.	LIGHT DUTY HOUSE HOLD

An extensive series of tests and design requirements determines which Duty Rating a particular ladder may be labelled with. The total load supported includes the combined weight of the user, clothing, tools and any material on the ladder. The tests' requirements have been specified with a safety factor of four to ensure the ability to meet the Duty Rating. However, ladders must be used properly in order to support the intended load.

But users make ladders more safe :

Although the ladders are rigidly constructed they can be involved in the accident if proper care / cautions are not taken in its use. All instructions and labels on ladders to be read before use.

Inspection before each use of ladder :

- Inspect the ladder thoroughly for missing or damaged components before using a ladder.
- Never use a damaged ladder & also never make temporary repairs. Inspect thoroughly for loose fasteners.
- Make sure all working & moving parts are in good working condition, if required lubricate the same. Clean ladder from all foreign materials like water, mud, grease, oil etc.

Consider before each use of ladder :

- Metal Ladder conduct Electricity hence keep away from electrical circuits. Use FRP ladders instead of metal ladders as metal ladders conduct electricity.
- We request you to use ladder as per the instruction, do not overload it. It is designed for one person only. Do not use in poor health, or alcoholic conditions or physically handicapped condition.
- Keep shoes clean & do not use leather shoes while using ladder.
- Never leave ladder set up & unattended.

For more details on instructions to use the ladders ask for technical manual for ladder safety of FRP Ladders.

FEATURES OF FIBERGLASS LADDERS :

• NON CONDUCTIVE	• LIGHT IN WEIGHT
• CORROSION RESISTANCE	• SHOCK PROOF
• SIDE RAILS FROM PULLTRUDED CHANNEL	• UV STABILIZED
• FLAME RETARDANT	• ECONOMICAL IN LONG RUN
• HIGH STRENGTH TO WEIGHT RATIO	• LOW THERMAL CONDUCTIVITY

OUR CURRENT RANGE OF LADDERS :

Series	Description	Capacity	Duty Rating
FS 1000	SELF SUPPORTED STEP LADDER	300LBS	TYPE IA
FS 2000	SELF SUPPORTED STEP LADDER	250LBS	TYPE I
FM 1000	SELF SUPPORTED STEP TRESTLE LADDER	300LBS	TYPE IA
FM 2000	SELF SUPPORTED STEP TRESTLE LADDER	250LBS	TYPE I
FH 1000	WALL SUPPORTED SHELF LADDER	300LBS	TYPE IA
FP 1000	SELF SUPPORTED PLATFORM LADDER	300LBS	TYPE IA
FP 1100	SELF SUPPORTED PLATFORM LADDER WITH HAND RAIL & CASTOR	300LBS	TYPE IA
FP 3000	SELF SUPPORTED TRESTLE LADDER WITH FOLDABLE PLATFORM	300LBS	TYPE IA
FE 2000	WALL SUPPORTED EXTENSION LADDER	300LBS	TYPE IA
FE 3000	WALL SUPPORTED EXTENSION LADDER	300LBS	TYPE IA
FE 8400	LADDER FOR MANHOLE APPLICATION	300LBS	TYPE IA
FY 8000	INDUSTRIAL STEP STAND	300LBS	TYPE IA
FPM 1000	MOBILE PLATFORM FOR MAINTENANCE (SINGLE)	300LBS	TYPE IA
FPM 1100	MOBILE PLATFORM FOR MAINTENANCE (DOUBLE)	600LBS	TYPE IA
MTPL 1000	MOBILE TELESCOPIC PLATFORM LADDER	300LBS	TYPE IA
MTPL 2000	MOBILE TELESCOPIC PLATFORM TILTABLE LADDER	300LBS	TYPE IA
FPM 3000	MOBILE PLATFORM LADDER FOR MAINTENANCE	300LBS	TYPE IA

USE THESE CHARTS TO DETERMINE THE RIGHT LADDER LENGTH FOR YOUR JOB :

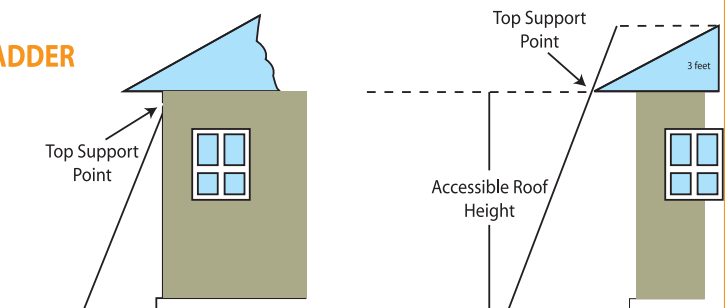

STEP LADDER HEIGHT SELECTION GUIDE

STEP LADDER SIZE	APPROX, HIGHEST STANDING LEVEL
4'	1' 11"
5'	2' 11"
6'	3' 9"
7'	4' 9"
8'	5' 8"
10'	7' 7"
12'	9' 6"
14'	11' 5"
16'	13' 4"
18'	15' 3"
20'	17' 2"

EXTENSION LADDER LENGTH SELECTION GUIDE

LADDER SIZE	MAXIMUM EXTENDED LENGTH	*WORKING RANGE TO TOP SUPPORT	*MAXIMUM ACCESSIBLE ROOF HEIGHT RANGE
16'	13'	7-1/2' - 12-1/2'	4-1/2' - 9-1/2'
20'	17'	9-1/2' - 16-1/2'	6-1/2' - 13-1/2'
24'	21'	11-1/2' - 20'	8-1/2' - 17'
28'	25'	13-1/2' - 24'	10-1/2' - 21'
32'	29'	15-1/2' - 28'	12-1/2' - 25'
36'	32'	17-1/2' - 31'	14' - 28'
40'	35'	19' - 33-1/2'	16' - 30-1/2'
44'	39'	21' - 37-1/2'	18' - 34-1/2'
48'	43'	23' - 41-1/2'	20' - 38-1/2'
60'	48'	23' - 46-1/2'	20' - 43-1/2'

FIBERGLASS STEP LADDER



FS1000 SERIES 300 lbs.



Extra heavy duty fiberglass step ladder for all industrial applications.

Moulded top with Recess tray : Nonconductive Structural moulded top, with slots help to keep tools close at hand.

Inside Spreader Braces

Slip Resistant Rubber Feet : Aluminum Feet with thick rubber tread.

Full Channel Fiberglass : Nonconductive.

Heavy Gusset Bracing : Two pairs of gusset support at the bottom step. All gussets are heavy duty steel.

Sumip Model	Size	Step Size	Width	Approx. Spread.	Approx. Wt.	Approx. Cube
FS 1003	3FT	3"	17.5"	23"	6	3.23'
FS 1004	4FT	3"	19"	29"	8	4.05'
FS 1005	5FT	3"	21.5"	35"	9.5	5.17'
FS 1006	6FT	3"	23"	41"	11	6.2'
FS 1007	7FT	3"	24.5"	48"	13	7.86'
FS 1008	8FT	3"	26"	54"	15	9.5'
FS 1010	10FT	3"	29"	66"	19	12.54'
FS 1012	12FT	3"	32"	78"	24	16.10'

FIBERGLASS STEP LADDER

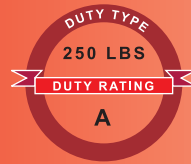

FS2000 SERIES 250 lbs.



A heavy duty fiberglass step ladder for light and general industrial use.

Moulded top with Recess tray : Nonconductive Structural moulded top, with slots help to keep tools close at hand.

Pinch proof Spreader Braces : Heavy duty plated steel spreader braces with double rivet hinge - this protect the user from pinched finger.

Slip Resistant Rubber Feet : Aluminum Feet with thick rubber tread.

Full Channel Fiberglass : Nonconductive full channel rails with polyester veil.

Sumip Model	Size	Step Size	Width	Approx. Spread.	Approx. Wt.	Approx. Cube
FS 2004	4FT	3"	19"	29"	5	4.05'
FS 2005	5FT	3"	21.5"	35"	6.5	5.17'
FS 2006	6FT	3"	23"	41"	7.5	6.2'
FS 2008	8FT	3"	24.5"	48"	12	9.5'

FIBERGLASS STEP TRESTLE LADDER



FM1000 SERIES 300 lbs.



Two side mechanical step ladder is designed as trestle ladder for entry from either side. Nonconductive fiberglass rail with fully serrated aluminum steps on front & back.

Heavy Gauge Steel Hinges : Suitable for industrial application.

Heavy Gusset Bracing : Two pairs of gusset support at the bottom step. All gussets are heavy duty steel.

Slip Resistant Rubber Feet : Aluminum feet with thick rubber tread.

Inside Spreader Braces : (Through 12')

Full Channel of Fiberglass Rail.

Sumip Model	Size	Step width	Bottom Width	Approx. Spread	Approx. Wt.	Approx. Cube
FM 1004	4FT	3"	19"	36"	10.5	4.05'
FM 1005	5FT	3"	21.5"	45"	12	5.01'
FM 1006	6FT	3"	23"	52"	13	6.53'
FM 1007	7FT	3"	24.5"	60"	17	8.10'
FM 1008	8FT	3"	26"	67"	20	9.51'
FM 1010	10FT	4"	29"	83"	27	13.44'
FM 1012	12FT	4"	32"	98"	33	17.25'
FM 1014	14FT	4"	35"	112"	38	22.50'
FM 1016	16FT	4"	38"	127"	45	27.50'
FM 1018	18FT	4"	41"	142"	51	33.00'
FM 1020	20FT	4"	42"	145.5"	53	39.00'

FIBERGLASS STEP TRESTLE LADDER



FM2000 SERIES 250 lbs.



Two side mechanical step ladder is designed as trestle ladder for entry from either side. Nonconductive fiberglass rail with fully serrated aluminum steps on both the side.

Heavy Gauge Steel Hinges : Suitable for industrial application.

Pinch proof Spreader Braces : Heavy duty plated steel spreader braces with double rivet hinge - these protect the user from pinched fingers.

Full Channel of Fiberglass : Nonconductive full channel rails with polyester veil.

Slip Resistant Rubber : Aluminum feet with thick rubber tread.

Sumip Model	Size	Step width	Bottom Width	Approx. Spread	Approx. Wt.	Approx. Cube
FM 2004	4FT	3"	19"	36"	9	4.05'
FM 2005	5FT	3"	21.5"	45"	10	5.01'
FM 2006	6FT	3"	23"	52"	10.5	6.53'
FM 2007	7FT	3"	24.5"	60"	14	8.10'
FM 2008	8FT	3"	26"	67"	17	9.51'
FM 2010	10FT	3"	29"	83"	23	13.44'
FM 2012	12FT	3"	32"	98"	28	17.25'

FIBERGLASS SHELF LADDER



FH1000 SERIES 300 lbs.



Extra heavy duty 300lb rated, shelf ladder for all industrial application. Steps are level when the ladder is set at 18 Degree. Nonconductive fiberglass side rail with fully serrated aluminum step.

Rubber Bumper : Thick rubber of 6" length parallel to sides of ladder.

Heavy Gusset Bracing : Two pairs of gusset support at the bottom step. All gussets are heavy duty steel.

Slip Resistant Rubber Feet : Aluminum feet with thick rubber tread.

Sumip Model	Total Length	Step Size	Width	Approx. Wt.	Approx. Cube.
FH 1004	4FT	3"	15"	4.0	1.25'
FH 1005	5FT	3"	15"	5.0	1.56'
FH 1006	6FT	3"	15"	6.0	1.87'
FH 1007	7FT	3"	15"	8.0	2.18'
FH 1008	8FT	3"	15"	8.5	2.50'
FH 1010	10FT	3"	15"	10.5	3.12'
FH 1012	12FT	3"	15"	12.5	4.95'
FH 1014	14FT	4"	17"	15.5	6.54'
FH 1016	16FT	4"	17"	18	7.50'
FH 1018	18FT	4"	17"	20	8.43'
FH 1020	20FT	4"	17"	22	9.37'

FIBERGLASS MANHOLE LADDER



FE8400 SERIES 300 lbs.



← Shown with optional rail protectors

A narrow fiberglass Straight Ladder design for use in manholes. Full Channel nonconductive side rails. Width of all sizes are 14".

Round Fully Serrated Tempered Rungs.

Optional Rail Protector : Can be ordered with durable rail guards to protect the side rail from metallic rim of manhole.

Safety Shoes : Aluminum Shoe with thick rubber tread.

Full Channel Fiberglass Channel : Nonconductive.

Sumip Model	Total Length	Approx. Wt.	Approx. Cube.
FE 8408	8'	9	2.5'
FE 8410	10'	11	3.48'
FE 8412	12'	13	4.2'
FE 8414	14'	16	5.0'
FE 8416	16'	17	5.6'
FE 8418	18'	20	6.5'
FE 8420	20'	21	7.0'

Size	Raill depth	Approx Inside width	Approx Outside width
8-12'	3-1/4"	11.5/8"	14"
14-20'	4"	11.5/8"	14"

FIBERGLASS EXTENSION LADDER



FE2000 SERIES 300 lbs.



Heavy Duty channel extension ladder for all industrial application. Full channel nonconductive side rails. Set ladder at the proper working angle.

Round Fully Serrated Tempered Rungs : Rungs are connected with Plates.

Easy one handed locking system.

Swivel Safety Shoes : Aluminum Shoe with thick rubber tread.

Full Channel Fiberglass Channel : Nonconductive.

Sumip Model	Total Length	Length of section	Exten. Height	Approx. Wt.	Approx. Cube.
FE 2616	16'	8'	13'	21	7.8'
FE 2620	20'	10'	17'	23	9.54'
FE 2624	24'	12'	21'	28	11.34'
FE 2628	28'	14'	25'	32	13.23'
FE 2632	32'	16'	29'	36	15.12'
FE 2636	36'	18'	32'	40	17.01'
FE 2640	40'	20'	35'	45	18.90'

Size	Rail depth	Total Ht.	Approx Inside width		Approx Outside width	
			Base	Fly	Base	Fly
16-40'	4"	6.5"	15"	14"	18"	16.5"

FIBERGLASS EXTENSION LADDER

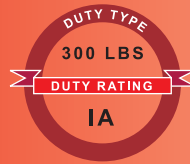

FE3000 SERIES 300 lbs.



Heavy Duty channel extension ladder for all industrial application. Full channel nonconductive side rails. Set ladder at the proper working angle.

Round Fully Serreted Tempered Rungs : Rungs are directly riveted on the side rails.

Easy locking system : Rope operated.

Safety Shoe : Thick Rubber Shoe.

Full Channel Fiberglass Channel : Nonconductive.

Sumip Model	Total Length	Length of section	Exten. Height	Approx. Wt.	Approx. Cube.
FE 3216	16'	8'	13'	23	7.58'
FE 3220	20'	10'	17'	23	9.54'
FE 3224	24'	12'	21'	28	11.34'
FE 3228	28'	14'	25'	32	13.23'
FE 3232	32'	16'	29'	36	15.12'
FE 3236	36'	18'	32'	40	17.01'
FE 3240	40'	20'	35'	45	18.90'

Size	Rail depth	Total Ht.	Approx Inside width		Approx Outside width	
			Base	Fly	Base	Fly
16-40'	4"	6.5"	15"	14"	18"	16.5"

FIBERGLASS PLATFORM STEP LADDER



FP1000 SERIES
300 lbs.



Fiberglass platform ladder designed for prolong standing at one height. Nonconductive fiberglass rail with fully serrated aluminium step & platform.

Slip Resistant Platform : Large Fully serrated platform 15" wide 20" deep, it locks ladder.

Heavy Gusset Bracing : Two pairs of gusset support at the bottom step. All gussets are heavy duty steel.

Slip Resistant Rubber Feet : Aluminum feet with thick rubber tread.

Top Rail Guard : to serve as a railing for working from platform.

Full Channel of Fiberglass Rail.

Sumip Model	Size	Step width	Approx. Spread	Width	Approx. Wt.	Approx. Cube
FP 1003	3FT	3"	30"	22"	10	3.65'
FP 1004	4FT	3"	38"	23.5"	12	5.06'
FP 1005	5FT	3"	43"	25"	14	6.56'
FP 1006	6FT	3"	50"	26.5"	16	8.15'
FP 1008	8FT	3"	62"	29.5"	22	11.62'
FP 1010	10FT	4"	75"	32"	29	15.31'
FP 1012	12FT	4"	88"	35"	34	19.50'
FP 1014	14FT	4"	100"	38"	39	23.5'
FP 1016	16FT	4"	114.5"	40.5"	45	30.5'

Note : Supporting Rod is available in 10 ft and above height models.

FIBERGLASS PLATFORM STEP LADDER



FP1100 SERIES
300 lbs.



Fiberglass platform ladder designed for prolong standing at one height. Nonconductive fiberglass rail with fully serrated aluminium step & platform

Slip Resistant Platform : Large Fully serrated platform 15" wide 20" deep, it locks ladder.

Heavy Gusset Bracing : Two pairs of gusset support at the bottom step. All gussets are heavy duty steel.

Slip Resistant Rubber Feet : Aluminum feet with thick rubber tread.

Top Rail Guard : To serve as a railing for working from platform.

Full Channel of Fiberglass Rail.

Sumip Model	Size	Step width	Approx. Spread	Width	Approx. Wt.	Approx. Cube
FP 1103	3FT	3"	30"	22"	10	3.65'
FP 1104	4FT	3"	38"	23.5"	12	5.06'
FP 1105	5FT	3"	43"	25"	14	6.56'
FP 1106	6FT	3"	50"	26.5"	16	8.15'
FP 1108	8FT	3"	62"	29.5"	22	11.62'
FP 1110	10FT	4"	75"	32"	29	15.31'
FP 1112	12FT	4"	88"	35"	34	19.50'

Note : 6, 8, 10 & 12 Models are provided with insulated handrail and 3, 4 & 5 Models are provided with castor unit only.

FIBERGLASS MOBILE MAINTENANCE PLATFORM

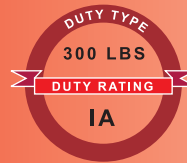

FPM1000 SERIES 300 lbs.



These mobile maintenance platform is specially designed for working around electricity, its non conductive material & heavy duty construction provides safety on jobs where electrical lines are present.

- Heavy Duty anti skid step assembly.
- Non conductive Platform Assembly.
- Heavy Duty Base Assembly.
- Non Conductive Handrail & Guard Rail.
- Safety Lock feature with Handle for Wheel Engagement.
- Safety Yellow Colour.

FPM1000 Series Single Person 24L X 17W 300LBS Capacity **FPM1100 Series Double Person 24L X 34W 600LBS Capacity**

Sumip Model	Size	HT to Step	Max Length	Max Width	Max HT with Side	WT in Kg.	Approx Cube	Sumip Model	Size	HT to Step	Max Length	Max Width	Max HT with Side	WT in Kg.	Approx Cube
FPM1005	5	4'	63"	32"	7'6"	79	18'	FPM1105	5	4'	80"	32"	7'6"	88	25'
FPM1006	6	4'9"	71"	32"	8'3"	86	21'	FPM1106	6	4'9"	92"	32"	8'3"	95	28'
FPM1007	7	5'7"	80"	32"	9'1"	106	25'	FPM1107	7	5'7"	97"	32"	9'1"	115	31'
FPM1008	8	6'4"	89"	32"	9'10"	117	28'	FPM1108	8	6'4"	106"	32"	9'10"	126	60'
FPM1009	9	7'2"	97"	32"	10'8"	127	31'	FPM1109	9	7'2"	114"	32"	10'8"	136	66'
FPM1010	10	7'11"	106"	32"	11'5"	184	60'	FPM1110	10	7'11"	123"	32"	11'5"	197	71'
FPM1011	11	8'9"	114"	36"	12'3"	193	66'	FPM1111	11	8'9"	131"	36"	12'3"	207	77'
FPM1012	12	9'6"	123"	36"	13'	200	71'	FPM1112	12	9'6"	140"	36"	13'	214	83'
FPM1013	13	10'4"	131"	39"	13'10"	233	77'	FPM1113	13	10'4"	148"	39"	13'10"	246	89'
FPM1014	14	11'1.5"	140"	39"	14'10"	241	83'	FPM1114	14	11'1.5"	157"	39"	14'10"	255	95'
FPM1015	15	11'11"	148"	39"	15'5"	248	89'	FPM1115	15	11'11"	166"	39"	15'5"	261	101'

FIBERGLASS INDUSTRIAL STEP STAND

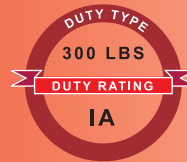

FY8000 SERIES 300 lbs.



These multi purpose, heavy duty industrial domestic step stands are available as light weight, non conductive fiberglass step stand.

- Large Moulded Top** : Nonconductive moulded top. 14" wide & 10" deep.
- Heavy Gusset Bracing** : Two pairs of gusset support at the bottom step. All gussets are heavy duty steel.
- Slip Resistant Rubber Feet** : Aluminum feet with thick rubber tread.
- Large Aluminum Fully Serrated Steps.**



Sumip Model	Size	Top width	Approx. Spread	Width	Approx. Wt.	Approx. Cube
FY 8001	1FT	14x10"	15"	15"	4	1.56'
FY 8002	2FT	14X10"	21"	18"	8	5.25'
FY 8003	3FT	14X10"	27"	20"	11	11.25'
FY 8004	4FT	14X10"	33"	22"	14	20.16'

Castor & handle option available

Note : Available Alternate FRP TOP CAP Size (A) 14 X 14" (B) 18 X 18" instead of 14 X 10"

OTHER PRODUCTS



MTPL 1000	MOBILE TELESCOPIC PLATFORM LADDER	
300 LBS DUTY RATING IA	This Ladder is Designed for Working on Street Light Application	SIZES 15FT to 30FT Platform Height



MTPL 2000	MOBILE TELESCOPIC PLATFORM TILTABLE LADDER	
300 LBS DUTY RATING IA	This Ladder is Designed for working on Street Light Application.	SIZES 15 FT to 25 FT Platform Height.



FPM 3000	MOBILE PLATFORM LADDER	
600 LBS DUTY RATING IA	This mobile maintenance platform is specially designed for working around electricity, its non conductive material & heavy duty construction provides safety on jobs where electrical lines are present. This ladder has a platform of size 600mm(W) X 800mm(L), which gives comfort to the user. The ladder has spring loaded castors, to move ladder easily.	SIZES 3FT To 6FT HEIGHT



FP 3000	SELF SUPPORTED TRESTLE LADDER WITH FOLDABLE PLATFORM	
300 LBS DUTY RATING IA	This platform ladder is self supported, design to be use by either side. The ladder has a castor for easy movement as well as platform is collapsible.	SIZES 6FT To 12FT HEIGHT

Note : The Ladders shown in the catalogue may or may not be final product due to continuous design improvement.

Step Ladder

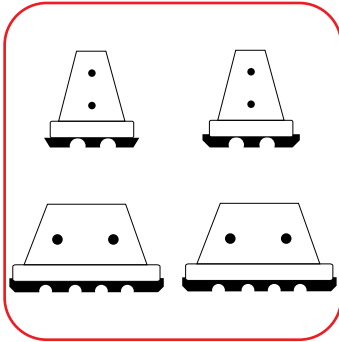

A Shoe Kits

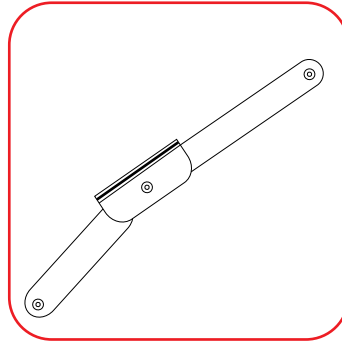

B Spreader Braces

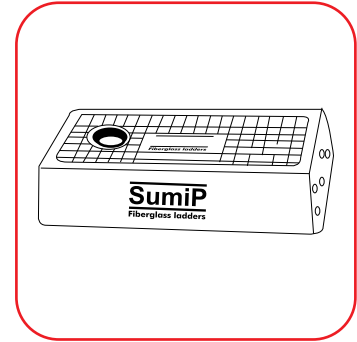

C Step Ladder Top

Extension Ladder

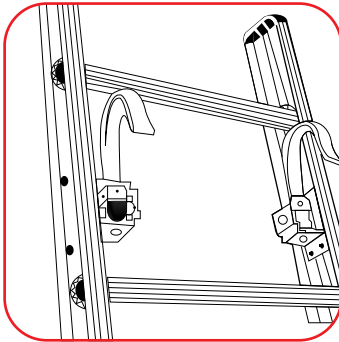

D Cable Hooks

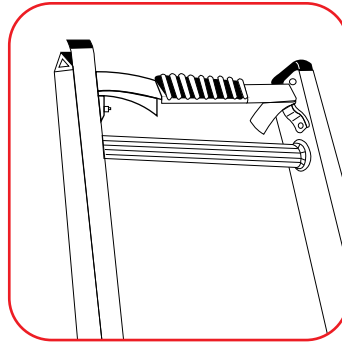

E Web Pole Grip

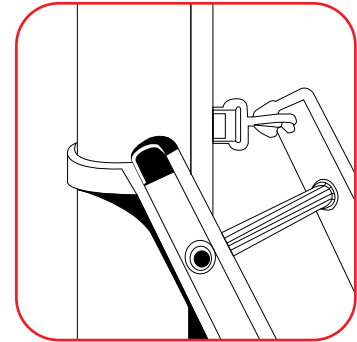

F Ladder Lash



G Rung Insulator

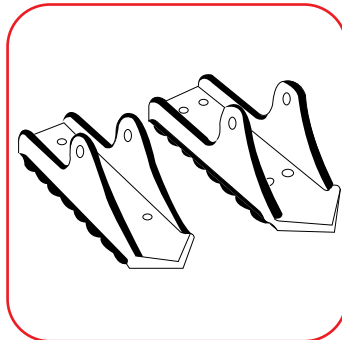

H Swivel Safety-Shoe Kits

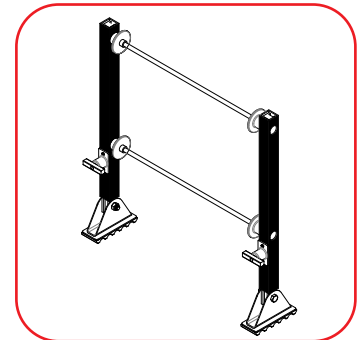

**I Leveler for FE type Ladder
(Also available for FH type Ladder)**

Notes :-

Exports

In India



Manufactured By:

M/s. Sumip Composites Pvt. Ltd.

Reg. Off.: 1 - 5, Panchratna Industrial Estate,
Sarkhej-Bavla Highway, Changodar,
Dist. Ahmedabad - 382 213, Gujarat (India).

Tele : +91 2717-610 700/712

E-mail : sales@sumip.com

Web : www.sumip.com

Marketed By :

Sumip Marketing Services

Panchratna Industrial Estate, Changodar,
Ahmedabad, Gujarat (India). E-mail : mktg@sumip.com