



# Enhancing business productivity through a wide range of **Checkweighing Solutions**

- High-Performance
- Excellent accuracy
- Easy integration



## Optimal Efficiency with Increased Precision

Prompt Automatic checkweigher are made of stainless steel, complying with the newest electrical safety regulations and meeting the highest demands for simple maintenance safety and usage, which belt system can be changed quickly by easy operation

## Online Checkweigher Series 100g, 600g, 1200g,6kg

Designed especially for pharma, food, spices, beverage, pesticides, vegetable, fodder, chemical industries



# Stable, Flexible and Accurate Design

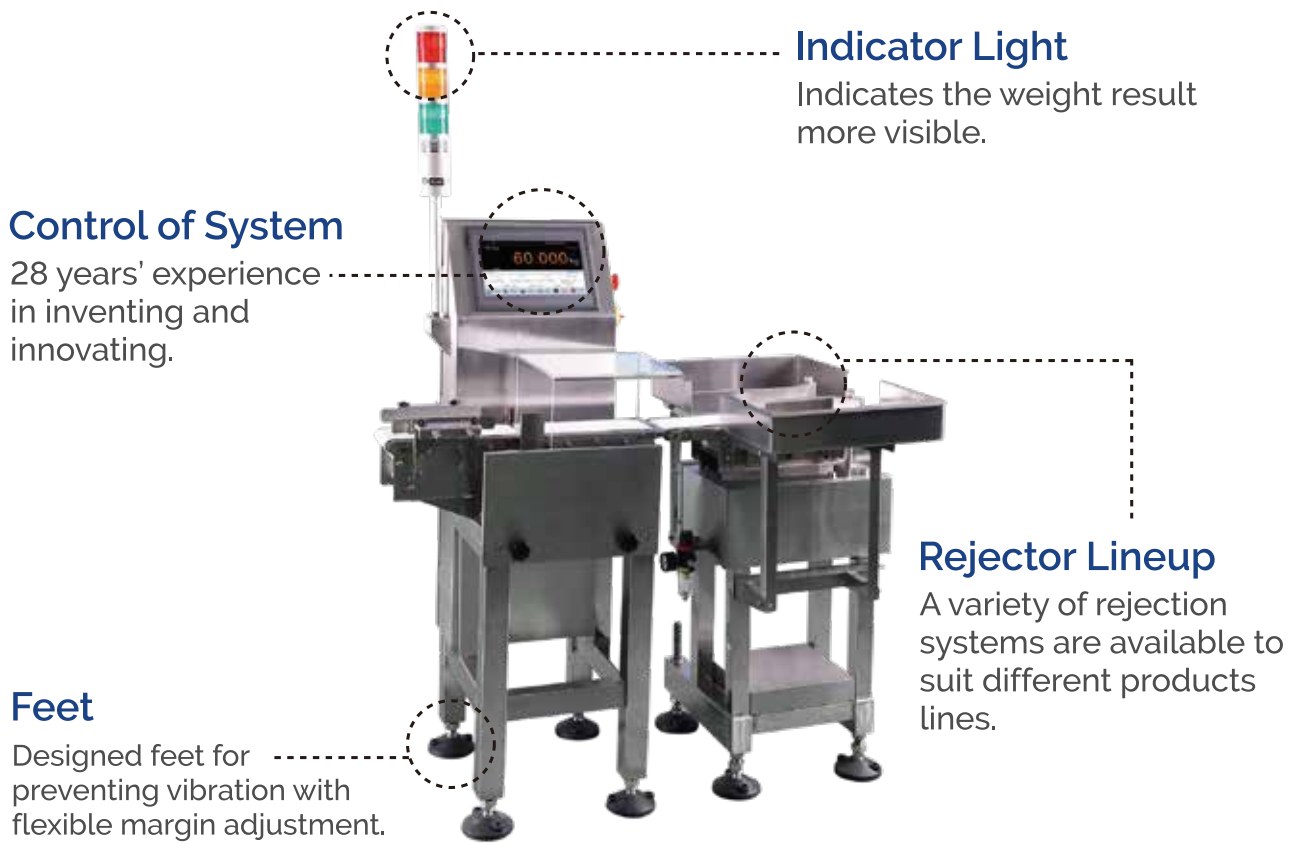

# High Efficient and Better Performance

## Quality Assurance

- Air protected wind shield reduces the influence of airflows to platform.
- Provide better performance and stable accuracy



## Adjustable Material Orientation Guider

- Ensure the object stable moving
- Decrease the vibration
- MOC- SS304



## Product Sensiorg

- Photoelectric sensors
- Enhance the accuracy and efficiency
- Better sensing the objects on and off platform.





# Control System

The compact and movable electric cabinet makes field installation and operation easier. External communication option with RS485 and Modbus TCP/IP.



# Mechanical Modular Design

Mechanical modular design makes transportation and maintenance more convenient, and enhances application adaptability..



## OIML Approved Loadcell

OIML approved loadcell with modular design facilitates maintenance and repairing.

## USB Memory Port



- Data acquisition
- Program updates

# Rejector Lineup

Flexible design of multi-rejector options: flap method, swing arm, push type .

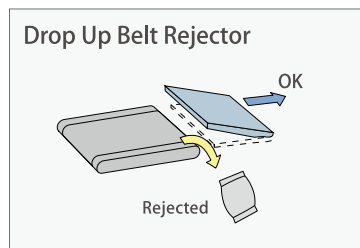
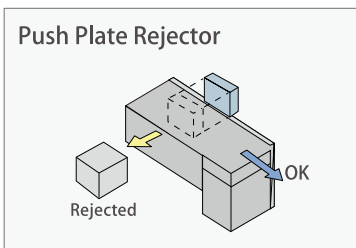
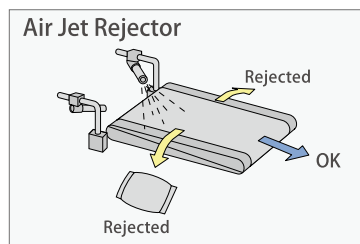
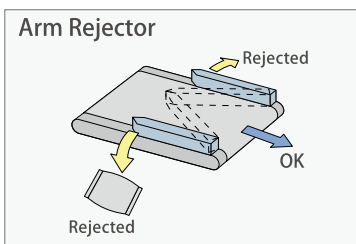

# User-Friendly Design

10-inch user friendly touch screen and graphical design interface. Simple operation and no need of any professional training.



- A million product formula storage. users/admin can easily add or delete data



- 3 levels of administration authority for well-organized management.



- Product formula with detection parameters setup by admin

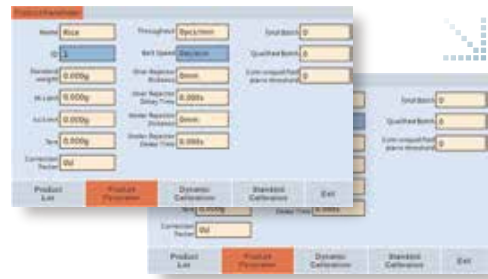

# Well-Organized Data Management

Weight fluctuation chart reflects the product's weight conditions from the macro perspective.

A million data details record including serial number, time and result for admin to check errors. Data summary report can be exported through USB and RS485



ID	Serial No.	Weight	Result	Time
0001				
0002				
0003				
0004				
0005				
0006				
0007				

# Checkweigher C101A-100g



- This product is widely used in Pharmaceutical production lines for highest weighing accuracy and repeatability.
- The checkweigher monitors manufacturing efficiencies and provides real-time data on your process. Product completeness and trends also provide feedback data to production line.
- It is also used in the application of checking completeness of secondary package to identify any missing items.



## The Pharmaceutical Industry



# Specification

Model	C101A-100G
Weighing range	5~100g
Accuracy	±0.2g
Weighing speed	180pcs/min
Belt speed	5~90meter/min
Platform size	275×133mm
Height	830±50mm
Belt size	250×100mm
Belt material	PU ( White )
Belt thickness	0.7mm
Tested object size	50~180×20~80×10~150mm
Display size	10 inch
Alarm light	3-color signal light
Alarm horn	optional
Holder/Frame material	304 stainless steel
Weigher platform material	304 stainless steel
Data storage	100 sets of parameters and 1 million weighing results
Communication	RS485 (Modbus RTU)/Modbus TCP/IP
Rejection mechanism	swing~arm type,air blowing type (optional)
Segments	3 levels
Air pressure	0.4~0.6 Mpa
IP grade	IP54

# Dimensions

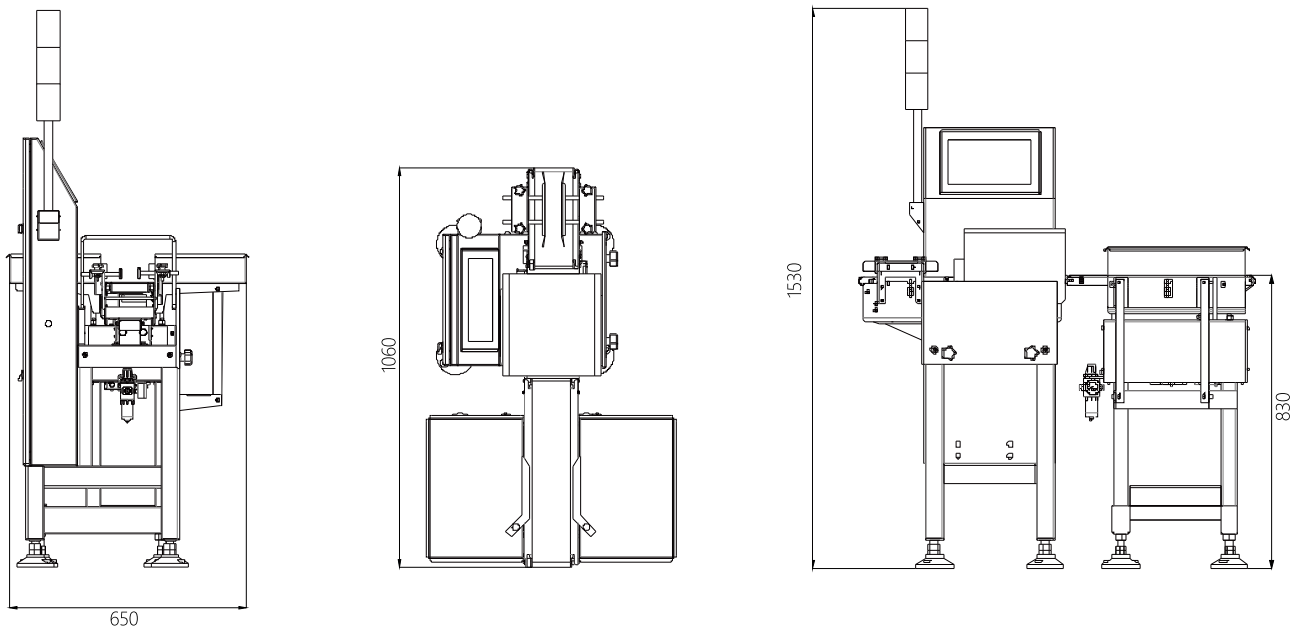



# Checkweigher C101A-600g

- This checkweigher is suitable for standard applications in food and other industries.
- System can store 100 product options for a wide variety of open or closed products in food and industrial production environments.
- System can be intergrated with metal detector



## Food and beverage





# Specification

Model	C101A-600G
Weighing range	5~600g
Accuracy	±0.5g
Weighing speed	300pcs/min
Belt speed	5~90meter/min
Plaform size	330×310mm
Height	750±50mm
Belt size	300×250mm
Belt material	PU ( White )
Belt thickness	0.7mm
Tested object size	50~240×20~150×10~180mm
Display size	10 inch
Alarm light	3-color signal light
Alarm horn	optional
Holder/Frame material	304 stainless steel
Weigher platformmaterial	304 stainless steel
Data storage	100 sets of parameters and 1 million weighing results
Communication	RS485 (Modbus RTU)/Modbus TCP/IP
Rejection mechanism	pusher,swing~arm type,flap type (optional)
Segments	3 levels
Air pressure	0.4~0.6 Mpa
IP grade	IP54

# Dimensions

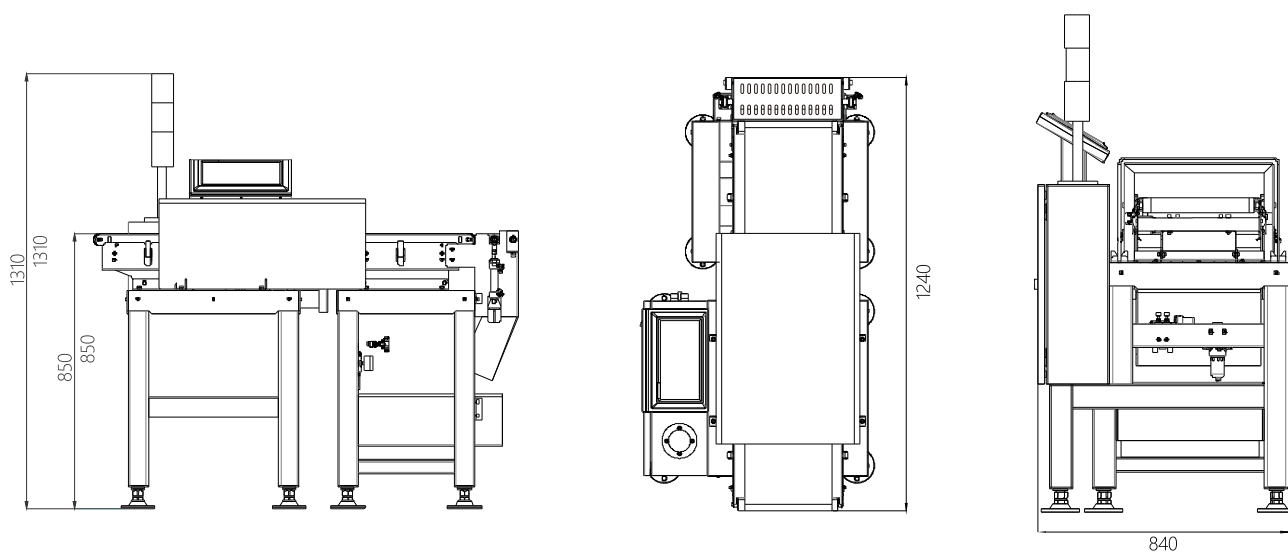

# Checkweigher C101A-1200g



- For pouches, bags, soft-sided containers and bottles.
- Standard S304 stainless steel frame
- 10-inch touch screen, can store over 1 million transaction, data export through USB.
- High speed at 150 pcs per min, within 0.5 gram accuracy.



## Multi-industry Application



# Specification

Model	C101A-1.2K
Weighing range	5~1200g
Accuracy	±0.5g
Weighing speed	150pcs/min
Belt speed	5~90meter/min
Plaform size	430×310mm
Height	750±50mm
Belt size	400×250mm
Belt material	PU ( White )
Belt thickness	0.7mm
Tested object size	50~300×20~220×10~220mm
Display size	10 inch
Alarm light	3-color signal light
Alarm horn	optional
Holder/Frame material	304 stainless steel
Weigher platformmaterial	304 stainless steel
Data storage	100 sets of parameters and 1 million weighing results
Communication	RS485 (Modbus RTU)/Modbus TCP/IP
Rejection mechanism	swing~arm type,flap type (optional)
Segments	3 levels
Air pressure	0.4~0.6 Mpa
IP grade	IP54

# Dimensions

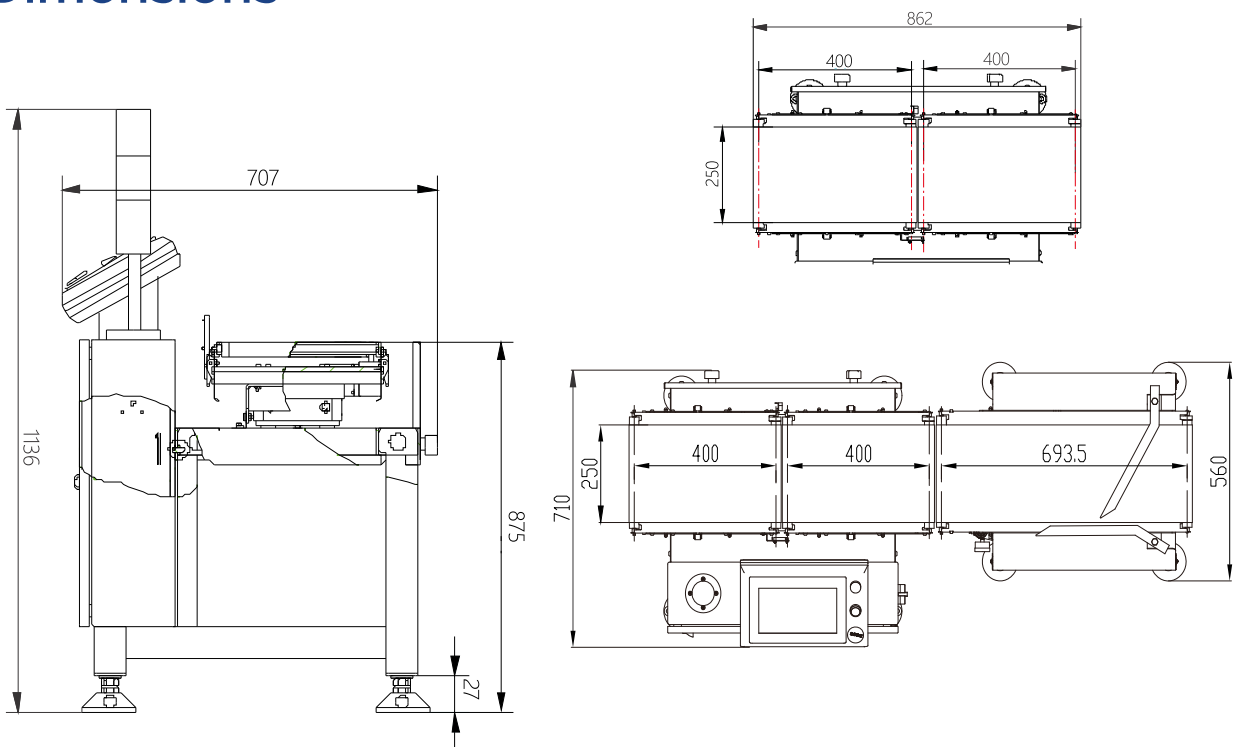



# Checkweigher C101A-6kg



## Multi-industry Application



# Specification

Model	C101A-6kg
Weighing range	1~6kg
Accuracy	±2~5g
Weighing speed	80pcs/min
Belt speed	0.1g
Products Dimension Specification	300*350mm
Troughput(PCS/min)	60PCS/min
Belt Dimension	L500mm*W400mm/L500mm*W400mm/L600mm*W400mm
Belt material	PVC ( White )
Conveyor belt high from ground	750mm±50mm
Flow direction	The flow direction is from left to right, with front side of machine is operator side.
Electrical rating	220volts AC 50Hz
Ambient temperature	0~40°C
Ambient humidity	90% Ambient humidity ( Uncondensed water )
Material	SS 304
Reject mechanism	pusher

# Dimensions

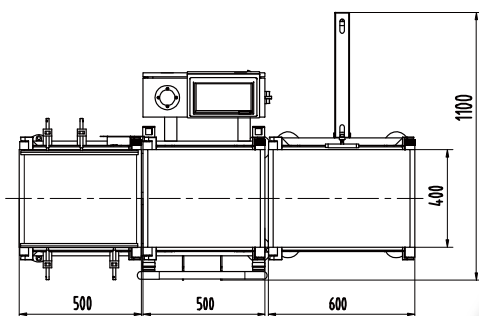
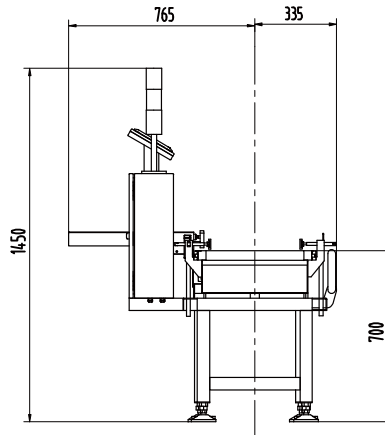
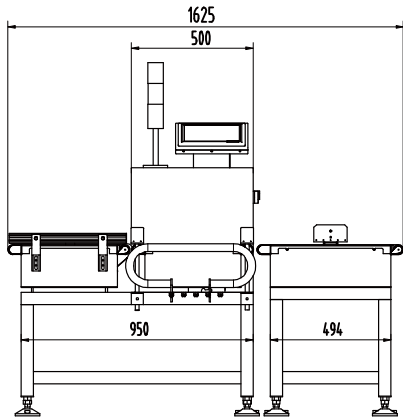

## PROMPT EQUIPMENTS PVT. LTD.

3-B, Vardan Exclusive, Nr. Stadium Petrol  
 Pump, Navrangpura, Ahmedabad, Gujarat – 380014  
 Phone: +91 79 26565981/82/83  
[www.promptscale.com](http://www.promptscale.com) | [sales@promptscale.com](mailto:sales@promptscale.com)