

IF IN DOUBT ASK.  
DO NOT MEASURE DRAWING

Surface finish Ra value-  
Roughness value no

N1 N2 N3 N4 N4 N5 N6 N7 N8 N9 N10 N11 N12

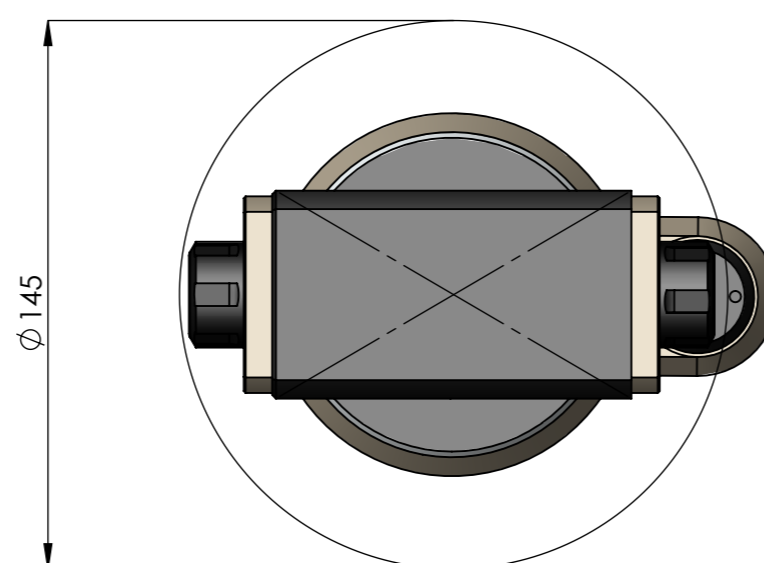
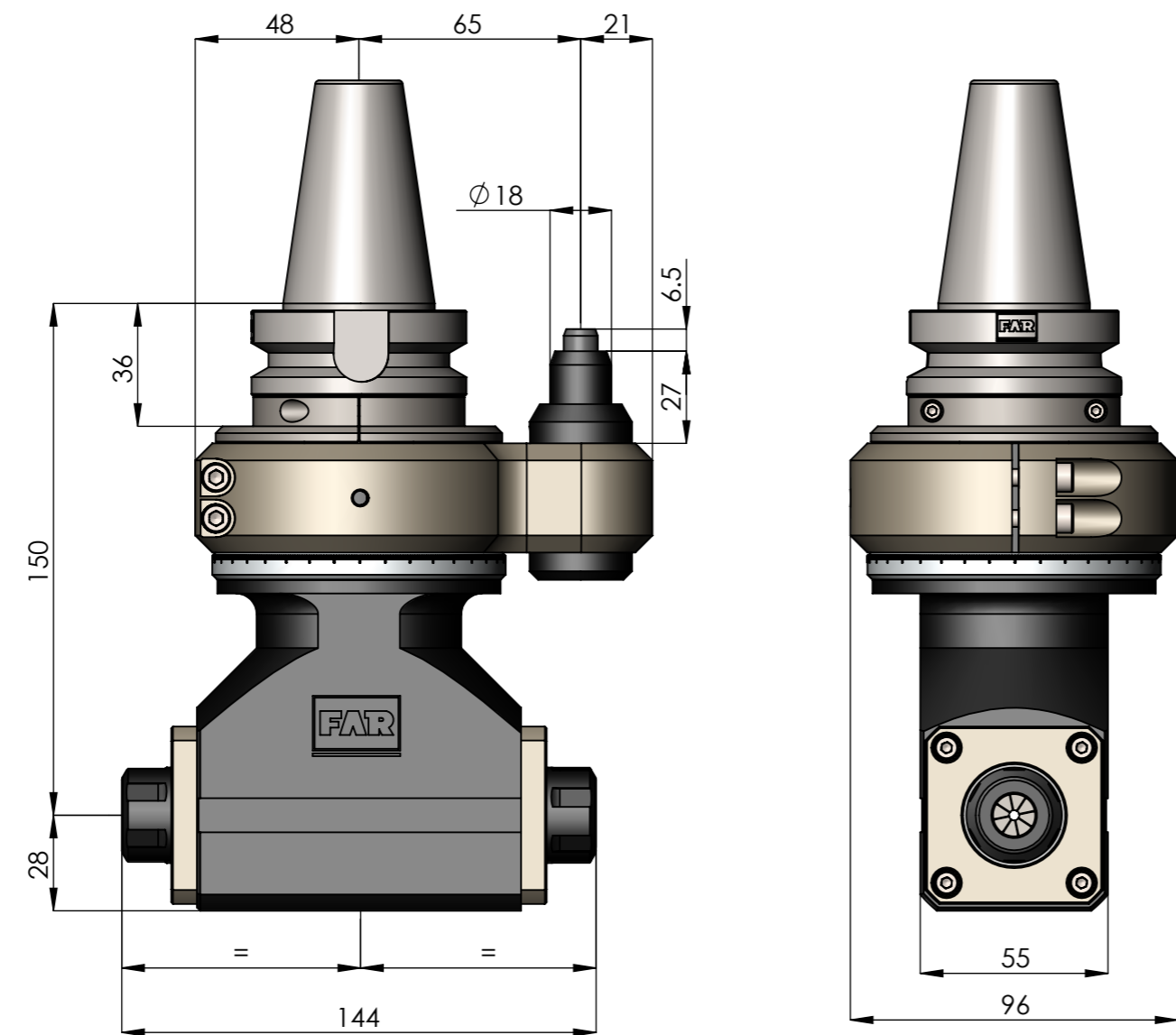
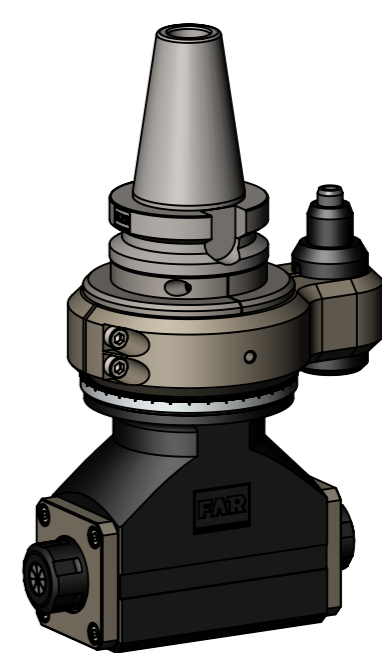

2-ER16-BT40	
	
Dual output collet	ER16
Input shank	BT40
Gear ratio	1:1
Speed	4000 RPM
Torque	12 Nm
Tool range	1-10 mm
Max.tap size	M8
Weight	5.8 Kg

- Direction of rotation is same as machine spindle
- Stop block design on machine head is based on machine details
- All dimensions are in 'mm'

Heat treatment	Hardness	Case depth

Semi product;	Final size:	Material:	Qty:	weight:	Scale:																																																																																																								
<table border="1"> <thead> <tr> <th>IS 2102-1969 GENERAL TOLERANCE Where not specified</th> <th>Alterations</th> <th>Advice no</th> <th>Description</th> <th>No of places</th> <th>Old no</th> <th>Name</th> <th>Date</th> </tr> </thead> <tbody> <tr> <td>Linear dimension over upto Tol.</td> <td></td> <td></td> <td></td> <td></td> <td></td> <td></td> <td></td> </tr> <tr> <td>0.5 6 ±0.1</td> <td></td> <td></td> <td></td> <td></td> <td></td> <td></td> <td></td> </tr> <tr> <td>6 30 ±0.2</td> <td></td> <td></td> <td></td> <td></td> <td></td> <td></td> <td></td> </tr> <tr> <td>30 120 ±0.3</td> <td></td> <td></td> <td></td> <td></td> <td></td> <td></td> <td></td> </tr> <tr> <td>120 315 ±0.5</td> <td></td> <td></td> <td></td> <td></td> <td></td> <td></td> <td></td> </tr> <tr> <td>315 1000 ±0.8</td> <td></td> <td></td> <td></td> <td></td> <td></td> <td></td> <td></td> </tr> <tr> <td>1000 2000 ±1.2</td> <td></td> <td></td> <td></td> <td></td> <td></td> <td></td> <td></td> </tr> <tr> <td>Angular dimension over upto Tol.</td> <td></td> <td></td> <td></td> <td></td> <td></td> <td></td> <td></td> </tr> <tr> <td>0 10 ±1</td> <td></td> <td></td> <td></td> <td></td> <td></td> <td></td> <td></td> </tr> <tr> <td>10 50 ±30</td> <td></td> <td></td> <td></td> <td></td> <td></td> <td></td> <td></td> </tr> <tr> <td>50 120 ±20</td> <td></td> <td></td> <td></td> <td></td> <td></td> <td></td> <td></td> </tr> <tr> <td>120 400 ±10</td> <td></td> <td></td> <td></td> <td></td> <td></td> <td></td> <td></td> </tr> </tbody> </table>						IS 2102-1969 GENERAL TOLERANCE Where not specified	Alterations	Advice no	Description	No of places	Old no	Name	Date	Linear dimension over upto Tol.								0.5 6 ±0.1								6 30 ±0.2								30 120 ±0.3								120 315 ±0.5								315 1000 ±0.8								1000 2000 ±1.2								Angular dimension over upto Tol.								0 10 ±1								10 50 ±30								50 120 ±20								120 400 ±10							
IS 2102-1969 GENERAL TOLERANCE Where not specified	Alterations	Advice no	Description	No of places	Old no	Name	Date																																																																																																						
Linear dimension over upto Tol.																																																																																																													
0.5 6 ±0.1																																																																																																													
6 30 ±0.2																																																																																																													
30 120 ±0.3																																																																																																													
120 315 ±0.5																																																																																																													
315 1000 ±0.8																																																																																																													
1000 2000 ±1.2																																																																																																													
Angular dimension over upto Tol.																																																																																																													
0 10 ±1																																																																																																													
10 50 ±30																																																																																																													
50 120 ±20																																																																																																													
120 400 ±10																																																																																																													
<p>PROPOSAL LAYOUT</p> 																																																																																																													
<p>Drawing no: MH-FXA-2-ER16-BT40-05-001-03</p>																																																																																																													
				No of sheets	Sheet no																																																																																																								