

IF IN DOUBT ASK.
DO NOT MEASURE DRAWING

Surface finish Ra value- Roughness value no

N1	N2	N3	N4	N4	N5	N6	N7	N8	N9	N10	N11	N12
----	----	----	----	----	----	----	----	----	----	-----	-----	-----

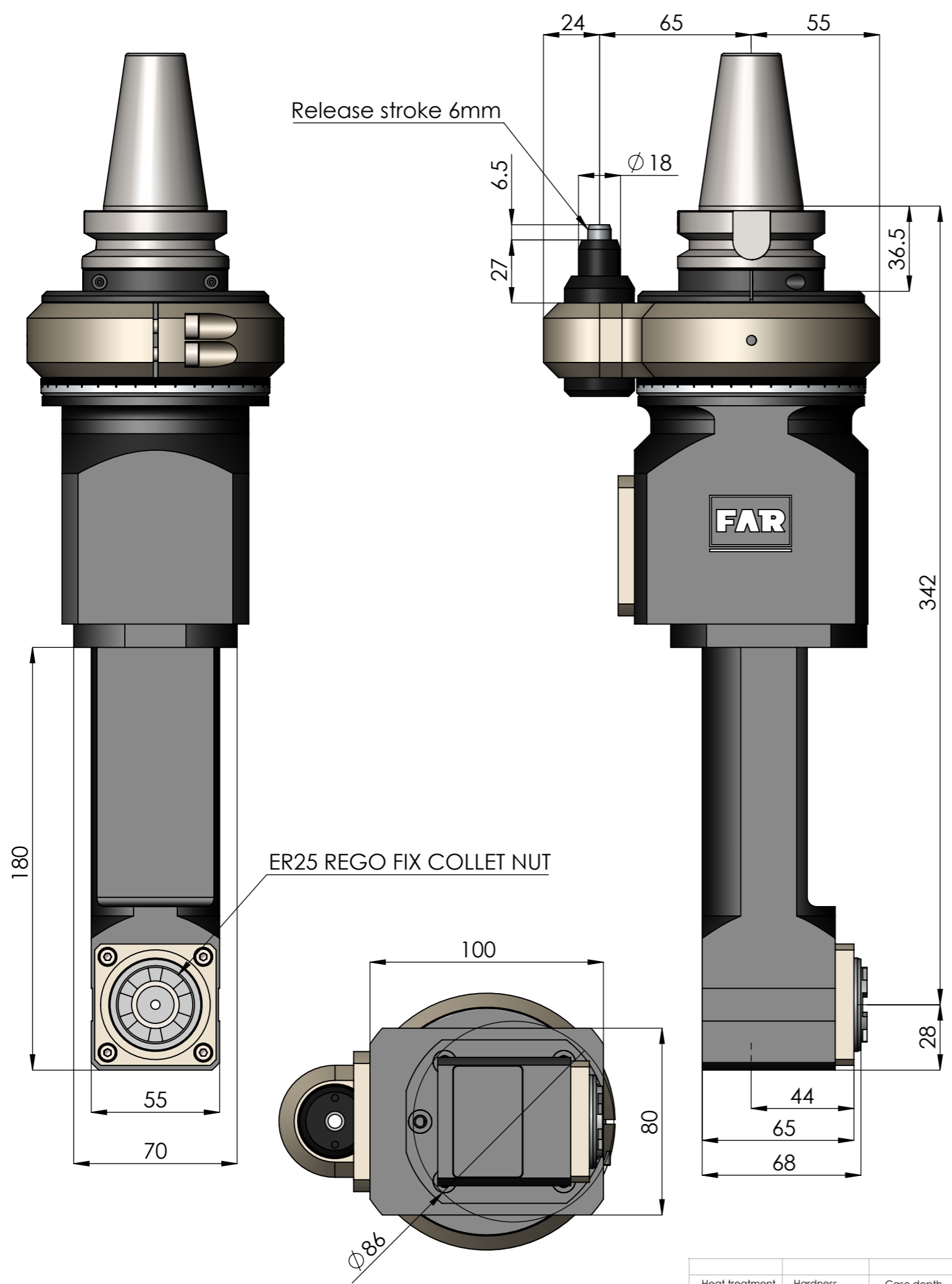

MH-FXA-ER25-BT40-SP1

Output collet	ER25
Input shank	BT40
Gear ratio	1.5(output) : 1(input)
Speed	4000 RPM
Torque	10 Nm
Tool range	Ø2-16 mm
Max. tap size	M12
Weight	10 Kg
Coolant type	Optional

1. Direction of rotation same as machine spindle
2. Stop block design on machine head is based on machine details
3. All dimensions are in 'mm'

Semi product;	Final size:	Material:	Qty:	weight:	Scale:																																																																																																																								
<table border="1"> <tr> <th>Linear dimension over</th> <th>upto</th> <th>Tol.</th> <th>Alterations</th> <th>Advice no</th> <th>Description</th> <th>No of places</th> <th>Old no</th> <th>Name</th> <th>Date</th> </tr> <tr> <td>0.5</td> <td>6</td> <td>±0.1</td> <td></td> <td></td> <td></td> <td></td> <td></td> <td></td> <td></td> </tr> <tr> <td>6</td> <td>30</td> <td>±0.2</td> <td></td> <td></td> <td></td> <td></td> <td></td> <td></td> <td></td> </tr> <tr> <td>30</td> <td>120</td> <td>±0.3</td> <td></td> <td></td> <td></td> <td></td> <td></td> <td></td> <td></td> </tr> <tr> <td>120</td> <td>315</td> <td>±0.5</td> <td></td> <td></td> <td></td> <td></td> <td></td> <td></td> <td></td> </tr> <tr> <td>315</td> <td>1000</td> <td>±0.8</td> <td></td> <td></td> <td></td> <td></td> <td></td> <td></td> <td></td> </tr> <tr> <td>1000</td> <td>2000</td> <td>±1.2</td> <td></td> <td></td> <td></td> <td></td> <td></td> <td></td> <td></td> </tr> <tr> <th>Angular dimension over</th> <th>upto</th> <th>Tol.</th> <td colspan="7"></td> </tr> <tr> <td>0</td> <td>10</td> <td>±1</td> <td colspan="7"></td> </tr> <tr> <td>10</td> <td>50</td> <td>±30</td> <td colspan="7"></td> </tr> <tr> <td>50</td> <td>120</td> <td>±20</td> <td colspan="7"></td> </tr> <tr> <td>120</td> <td>400</td> <td>±10</td> <td colspan="7"></td> </tr> </table>						Linear dimension over	upto	Tol.	Alterations	Advice no	Description	No of places	Old no	Name	Date	0.5	6	±0.1								6	30	±0.2								30	120	±0.3								120	315	±0.5								315	1000	±0.8								1000	2000	±1.2								Angular dimension over	upto	Tol.								0	10	±1								10	50	±30								50	120	±20								120	400	±10							
Linear dimension over	upto	Tol.	Alterations	Advice no	Description	No of places	Old no	Name	Date																																																																																																																				
0.5	6	±0.1																																																																																																																											
6	30	±0.2																																																																																																																											
30	120	±0.3																																																																																																																											
120	315	±0.5																																																																																																																											
315	1000	±0.8																																																																																																																											
1000	2000	±1.2																																																																																																																											
Angular dimension over	upto	Tol.																																																																																																																											
0	10	±1																																																																																																																											
10	50	±30																																																																																																																											
50	120	±20																																																																																																																											
120	400	±10																																																																																																																											
<p>PROPOSAL LAYOUT</p>																																																																																																																													
<p>Designation:</p>																																																																																																																													
<p>Drawing no: MH-FXA-ER25-BT40-SP1-05-001-03</p>																																																																																																																													
<p>No of sheets</p>				<p>Sheet no</p>																																																																																																																									

Heat treatment	Hardness	Case depth
----------------	----------	------------