

### SALIENT FEATURES

- Full bore type
- Suitable for conductive liquids
- Universal Power Supply 90 to 260V AC, Optional 24V DC
- Empty pipe indication
- Material option depending upon process data
- Local Indication through LCD
- HART Communication
- Communication port (Optional)
- Maintenance free
- Simple & cost effective construction
- Inbuilt Data Logger
- Inbuilt Relay Status output (High / Low / Batch)



### DESCRIPTION

Electronet series **ELMAG-200** are micro-controller based full bore type electromagnetic flow meters specially used for various industrial applications. These flow meters accurately measure the flow rate of conductive liquids & slurries in closed pipes. Due to its simple & rigid design, the flow meter is an obstruction-less & maintenance-free instrument in place of conventional mechanical flow measuring devices. The use of 'Pulsed DC' technology offers highest ability & better measuring accuracy in the form of electrical signal 4-20 mA DC linearly proportional to volumetric flow. The instrument is based on Faraday's law of electromagnetic induction. A magnetic field is generated by the instrument in the flow tube. The fluid flowing through this magnetic field generates a voltage that is proportional to the flow velocity. Corresponding electrical output is provided with respect to measuring flow range.

### TECHNICAL SPECIFICATIONS

Media	: Liquids (Conductive)
Conductivity	: > 5 $\mu\text{s/cm}$
Viscosity	: 200 cp max
Line Size	: 15 NB to 1000 NB
Excitation	: Pulsed DC
Type of Output	: 1) 4 to 20mA DC 2) 4 to 20mA DC + HART 3) 4 to 20mA DC + Pulse output 4) 4 to 20mA DC + HART + Pulse output
Display	: 16 x 2 LCD - 6 digit for Flow Rate & 8 digit for Totalizer Flow
Engineering Unit	: User Programmable ( $\text{m}^3/\text{hr}$ by default)
Calibration Range	: As per requirement (Factory Calibrated for std. 2m/s velocity)
Accuracy	: +/- 0.5% of M.V. (for 20 to 100% flow)
Linearity	: +/- 0.5% of M.V.
Repeatability	: +/- 0.2% of M.V.
Temperature Coefficient	: +/- 0.05% per $^{\circ}\text{C}$
Process Temperature	: 85 $^{\circ}\text{C}$ max for Rubber Lining & 220 $^{\circ}\text{C}$ for PTFE Lining
Process Pressure	: 10 kg/cm $^2$ max (higher on request)
Material of construction	: Lining - Neoprene Rubber / Hard Rubber / EPDM / PFA / PTFE Flange - MS / CS / Ss316 Electrode - SS 316L/ Hastalloy C / Platinum / Tantalum Coil Housing - MS / SS 304 / Ss316
Power Supply	: Option1 : 90 - 260 V AC, 50 Hz Option2 : 24 V DC
Power Consumption	: < 10 VA
Isolation	: 1.4 KV between Input, Output & Power Supply
Response Time	: < 1 Sec
Electronics	: Integral / Remote
Transmitter Enclosure	: Electronics : IP66, Flow Tube : Ip68
Process Connections	: ASA150 flanged, as per table B 16.5 (Other On Requirement)
Mounting	: In-Line Horizontal / Vertical
Operating Conditions	: Temperature -20 to 75 $^{\circ}\text{C}$ / Humidity 5 to 95% non condensing
Note :- For process conditions other than above please consult factory.	
<b>OPTIONAL :</b>	
Communication output	: 1) RS 485 supporting MODBUS RTU Protocol 2) GSM Communication (Add on Module)

## DIMENSIONAL DETAILS

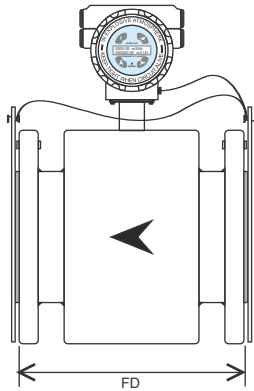

Fig. Front View

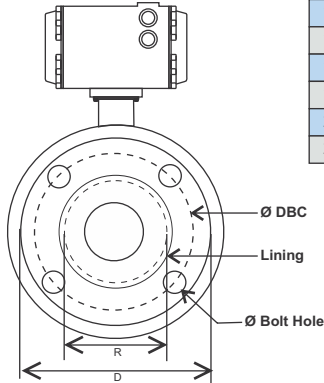

Fig. Side View

### DIMENSIONAL DETAILS OF FLANGE (AS PER ASA150 # B-16.5):

Line Size Inch	NB	Flange Diameter 'D'	Diameter of Raised Face 'R'	Diameter of Bolt Hole Circle 'DBC'	Diameter of Bolt Hole	No. of Holes	Flange Distance 'FD'	Flow Range (m/hr) at 0.3m/s to 6m/s	
								Minimum	Maximum
½"	15	88.9	34.9	60.3	15.9	4	200	0.19	3.817
¾"	20	98.4	42.9	69.8	15.9	4	200	0.33	6.785
1"	25	107.9	50.8	79.4	15.9	4	200	0.53	10.602
1 ½"	40	127.0	73	98.4	15.9	4	200	1.35	27.143
2"	50	152.4	92.1	120.6	19.0	4	200	2.12	42.4115
2 ½"	65	177.8	104.8	139.7	19.0	4	200	3.58	71.675
3"	80	190.5	127.0	152.4	19.0	4	200	5.42	108.573
4"	100	228.5	157.2	190.5	19.0	8	250	8.48	169.646
5"	125	254.0	185.7	215.9	22.2	8	250	13.25	265.071
6"	150	279.4	215.9	241.3	22.2	8	300	19.085	381.703
8"	200	342.9	269.9	298.4	22.2	8	350	33.929	678.584
10"	250	406.4	323.8	361.9	25.4	12	450	53.014	1060.28
12"	300	482.6	381.0	431.8	25.4	12	500	76.340	1526.81
14"	350	533.4	469.9	476.2	28.6	12	500	103.908	2078.16
16"	400	596.9	533.4	539.7	28.6	16	600	135.716	2714.33
18"	450	635.0	584.2	577.8	31.7	16	600	171.766	3435.33
20"	500	698.5	692.1	635.0	31.7	20	600	212.057	4241.15
24"	600	812.8	692.1	749.3	34.9	20	600	305.362	6107.25

### Note :

For Line size above 600NB consult factory.  
 Typical mounting dimensions for reference.  
 Standard factory calibration for 0.3 to 2 m/s velocity.  
 Flow meter should be selected with the help of Nomograph recommended full scale velocity.  
 Flow indication of 6 digit max. up to 999999

### Flow Nomograph

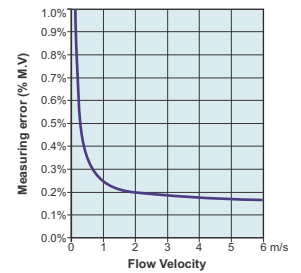
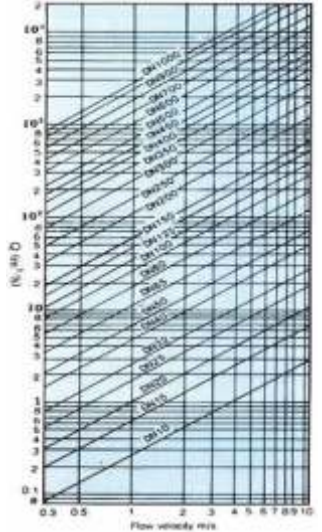

## INSTALLATION DRAWING

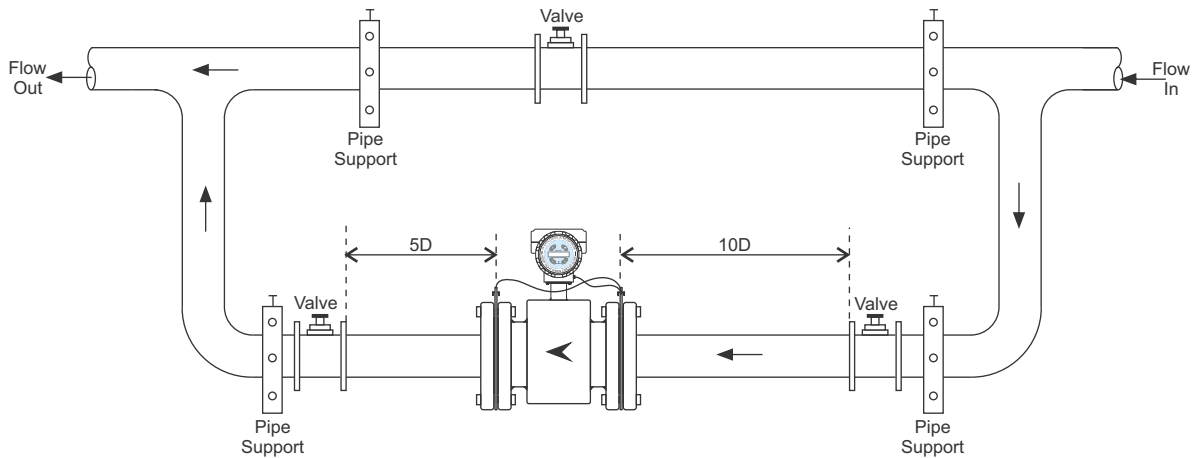

## ORDERING INFORMATION

Series	Line Size	Electronics	Electronic Enclosure	Lining Material	Flange Material	Flange Rating	Coil Housing	Electrode Material	Output	Power Supply	Comm. Output	Remote Cable Length	
ELMAG 200	A 15NB	B 01	C 01	D 01	E 01	F 01	G 01	H 01	I 01	J 01	K 01	L 01	
			02 Remote	02 SS 304	02 Hard Rubber	02 SS 316	08 Other	02 SS 316	02 Hyst. C	02 4-20mA + Pulse	02 24V DC	02 RS232	02 10mtr
	15NB To 1000NB	01 Local	01 Aluminum	01 Neoprene Rubber	01 MS/CS	01 ASA 150	01 MS	01 SS 316L	01 4-20mA	01 230V AC	01 RS485	01 5mtr	
				03 EPDM				03 Platinum	03 4-20mA + HART		03 GSM	03 25mtr	
				04 PFA				04 Tantalum	04 4-20mA + HART + Pulse				

\* Due to our continuous product improvisations, Design, Specifications and Model Number are subject to change without notice.  
 \* GSM output is without SIM card & SCADA viewing software. \* For better accuracy consult factory.

\* Accuracy defined at lab conditions.

### Authorised Dealer



*NK Instruments Pvt. Ltd.*

B-501/504, 5th floor, Raunak Arcade, Near THC Hospital, Gokhale Road, Naupada,  
 Thane(W) 400602. Maharashtra INDIA  
 E-Mail: sales@nkstruments.com  
 Skype: nitinkelkarskype

Telefax Nos.: 91-22-25301330 / 31 / 32  
 Web: http://www.nkinstruments.com  
 Gtalk: nkinstruments2006

