

WATER

HH80



Diesel Drive Auto Prime High Head Pump

HIMAX

The Himax Pump is a true self-priming pump so does not require manual priming of the suction line or filling of a priming tank in order to begin its normal operation.

The Sykes High Head range of pumpsets are fully automatic priming and designed to meet the stringent demands of the mining, construction and rental industries.

Boasting one of the best shaft stiffness ratio's of any automatic priming pump on the market, the Sykes High Head range provides the reliability to meet market expectations.

In addition the pump can run dry for extended periods due to the mechanical seal assembly which allows priming with long suction hoses and suction lifts of up to 9m (28 feet).

As fluid levels fluctuate, the pump will "snore" until the liquid is available for the pump to fully reprime itself automatically.

www.allightsykes.com

ALLIGHTSYKES



Features

- Low fuel usage
- Reduced engine sizes
- Lower maintenance costs
- Dry self prime and reprime
- Close coupled SAE Bearing Frames
- Suction lifts to 9m
- Operates in 'snore' conditions
- Vacuum Priming option available for ground dewatering.

- Diesel, electric or hydraulic drive
- Solids handling
- Simple maintenance
- Replaceable wear parts
- Chassis - skid, road tow, wheeled, caged
- Powered by Perkins or Cat Engines.
- Other engines available on request
- Custom build available
- Sykes purpose built Control panel

Application

- Construction
- Environmental
- Industrial
- Mining
- Clean Water
- Sludge
- Slimes
- Sewage
- Solids laden liquids
- Ground Dewatering
- Pipeline & Drilling
- Jetting
- Quarries

Technical Data

MATERIALS OF CONSTRUCTION

Pump Casing:	S.G. IRON 400/12
Suction Cover:	S.G. IRON 400/12
Air Separation Tank:	S.G. IRON 400/12
Bearing Bracket:	S.G. IRON 400/12
Pump Shaft:	431 Stainless Steel
Impeller:	316 Stainless Steel
Wearplates:	316 Stainless Steel
Mechanical Seal:	Silicon Carbide / Silicon Carbide
N.R.V. (Ball Type):	S.G. IRON 400/12

DESIGN DETAILS

Single Stage, end suction type, 3 vane open impeller, centrifugal pump

Suction Flange (mm/in):	75/3
Delivery Flange (mm/in):	75/3
Solids Handling Size (mm/in):	25/1
Maximum Head (m/ft):	105/344
Maximum Capacity:	28 L/sec

FUEL USAGE (L/HR) @ BEP

Speed (rpm)	POWER USAGE (kW)	FUEL RATE (L/hr)	RUN TIME (hrs - 250L fuel tank)
1400	10	2.47	101
2000	28	6.92	36
2400	44	10.87	23

CALCULATIONS BASED ON 210 g/kw.hr

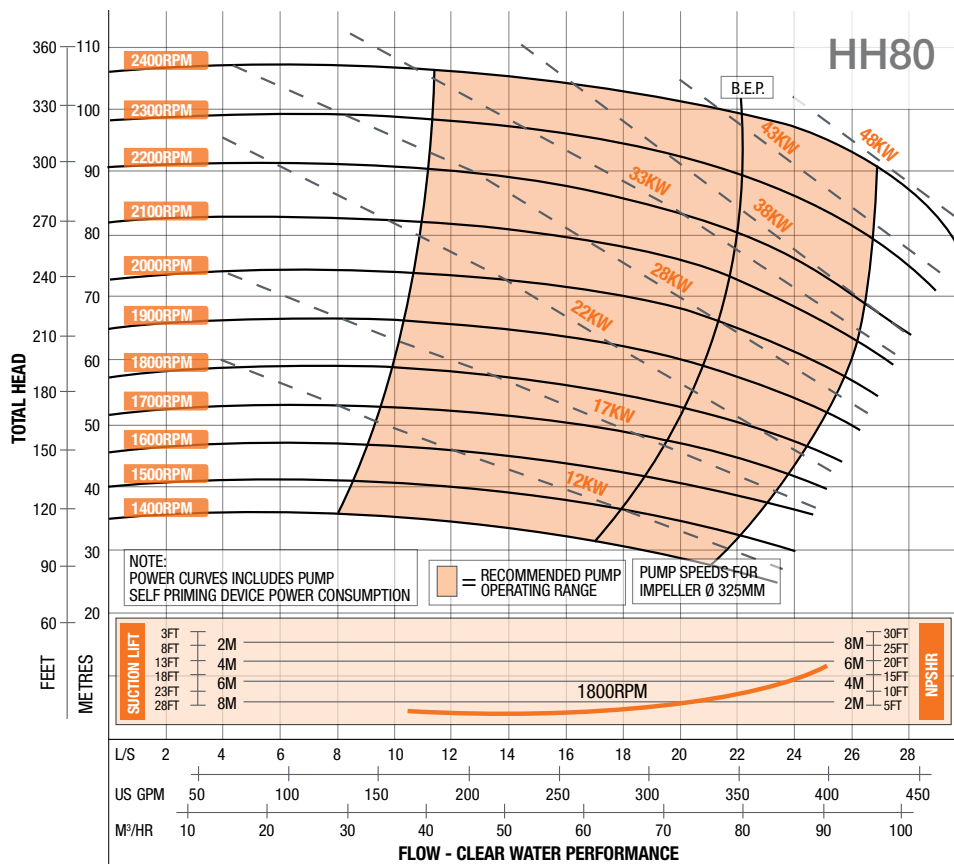

Dry Weight: 1510 kg
Fuel Capacity: 250 litres

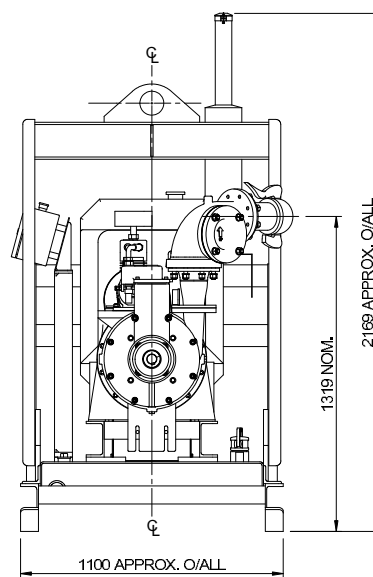
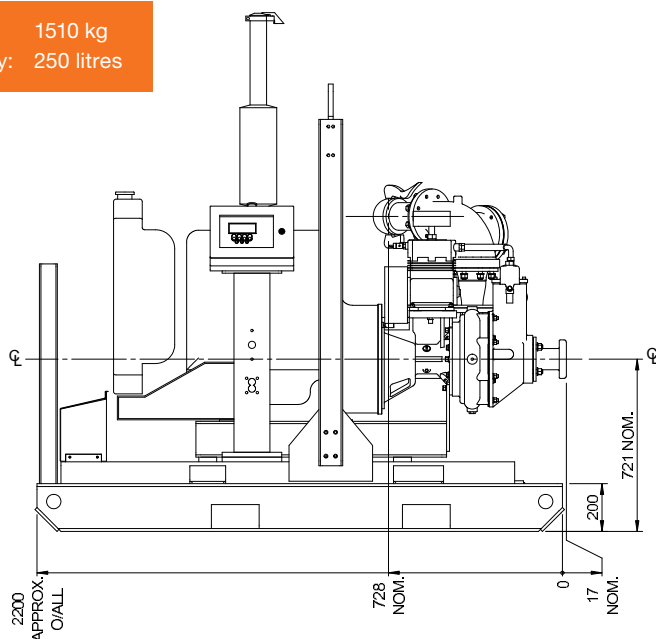

Final weight and dimensions will depend on completed specifications

All this information in this document is substantially correct at the time of printing and may be altered subsequently