



CE

Special Features

- Simple and compact design.
- High operating pressure up to 400 bar. (700 bar On Request)
- Over pressure safe from either side to maximum working pressure.
- Indicating mechanism isolated from pressure chamber.
- Suitable for Air / Gas media.

Application

- Filters
- Hydraulic systems
- Water treatment plants
- Chemical plants
- Natural gas processing
- Heat exchanger
- Gasoline / diesel engine filters
- Pumps
- Valves
- Compressors

Specifications

Standard Version : 40mm, 50mm, 63 mm, 100 mm & 150 mm

Accuracy	:	± 2.5% of F.S. (For ascending order)
Ambient temperature	:	Max. 65°C
Process temperature	:	Max. 80°C
Static pressure (on request)	:	upto 400 kg/cm ² for ranges 1 bar & Above
Over pressure range	:	same as Static Pressure
Connection	:	¼" NPT (F) x 2 Nos.

Case	:	AISI 304 SS
Wetted parts	:	Teflon, Ceramic Magnet & SS Spring
Body	:	AISI 316 SS
Protection	:	IP 65
Dial	:	Aluminum, black Colored, Fixed
Window	:	Plain Glass

Glycerine filled version (option py)

Accuracy	:	±4.0% of F. S. (For ascending order)
Ambient temperature	:	Maximum 65°C
Process temperature	:	Maximum 65°C
Window	:	Plexi Glass
Dampening liquids	:	Glycerin 99.7% (others available as option)
Other features	:	Refer Specification of Standard Version

Temperature effect :

The variation of indication caused by effects of temperature is to be calculated by below formula; which is to be added in the specified accuracy while measurement :- Formula : $\pm 0.04 \times (t_2 - t_1) \%$ of F. S. where t_1 = reference temperature (+20°C) and t_2 = ambient temperature in °C.

Operating Principle

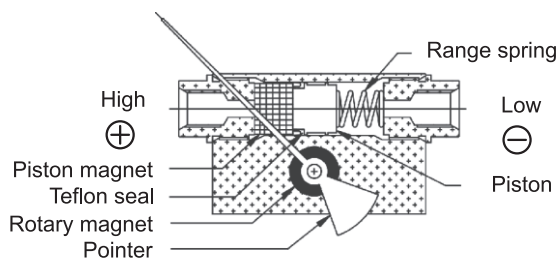

High and Low pressures are separated by a sensor assembly consisting of a magnet, piston, Teflon seal and a range spring. The difference in pressure causes the sensor assembly to move in proportion to the change against a range spring.

A rotary magnet, located in a separate body cavity and isolated from the acting pressures, is rotated by magnetic coupling as per the linear movement of the sensor assembly. A pointer attached to the rotary magnet indicates differential pressure on the dial.

Dimensions - standard version

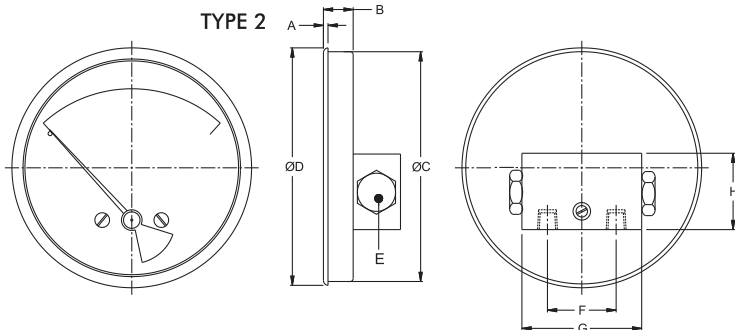

NS	A	B	ØC	ØD	E	F	G	H	Weight in gram (With Box)
63	12	17.0	62.5	70.0	25	54	77.5	50	430
100	12	22.0	100	111	25	54	77.5	50	460
150	15	22.0	148.5	161	25	54	77.5	50	560

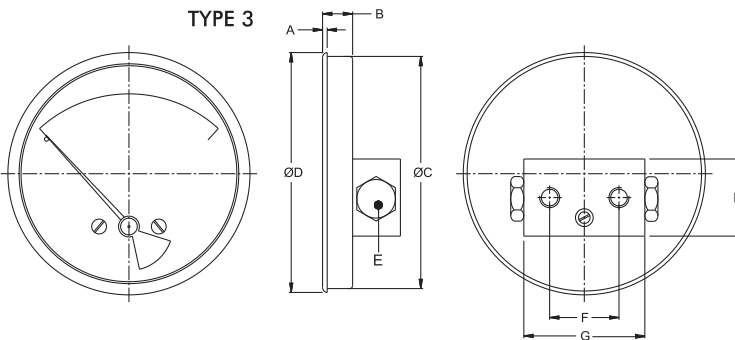

NS	A	B	ØC	ØD	E	F	G	H	Weight in gram (With Box)
63	12	17.0	62.5	70.0	25	54	77.5	50	400
100	12	22.0	100.0	111	25	54	77.5	50	450
150	15	22.0	148.5	161	25	54	77.5	50	540

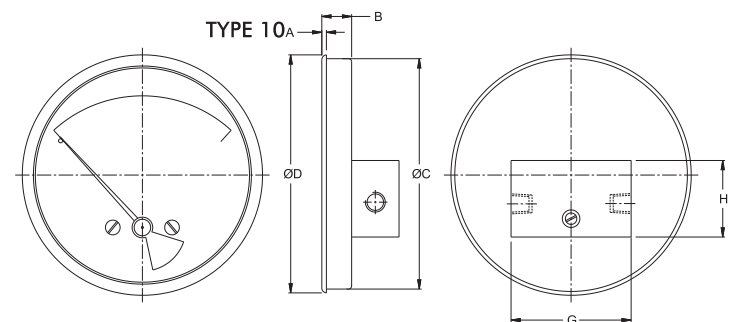

NS	A	B	ØC	ØD	E	G	H	Weight in gram (With Box)
63	12	17.0	62.5	70.0	25	77.5	50	400
100	12	22.0	100.0	111	25	77.5	50	450
150	15	22.0	148.5	161	25	77.5	50	540

Notes : • Drawings are not to scale. • All Dimensions are in mm. • NS = Nominal Size.

Range Table

Note : We offer National / International Scales like kPa, bar, psi, kg/cm², mbar, mmWC, inWC or Equivalent scales as per the requirement can be provided on request. Following are the example tables for kPa & kg/cm²

Gauge Pressure Range

Single scale					
kPa	kPa	kPa	kg/cm ²	kg/cm ²	kg/cm ²
0 / 100	0 / 350	0 / 900	0 / 1.00	0 / 3.50	0 / 9.00
0 / 160	0 / 400	0 / 1000	0 / 1.60	0 / 4.00	0 / 10.00
0 / 200	0 / 500		0 / 2.00	0 / 5.00	
0 / 250	0 / 600		0 / 2.50	0 / 6.00	
0 / 300	0 / 700		0 / 3.00	0 / 7.00	

Note : Other Scale are available on customer request.

How To Order						Example
Basic Model						DP1
Code						
Nominal Size	15	20	25	40	60	XX
	40 mm	50 mm	63 mm	100 mm	150 mm	
Case Type						
DM Case without front flange	PM Case with front flange					XX
Mounting						
2 Direct bottom entry	3 Direct back entry	10 In line entry				X OR XX
Body Material						
AL Aluminium	S6 AISI 316 SS	MO Monel				XX
Gauge Connection						
2NF 1/4" NPT (F) X 2 Nos. (Standard)	2BF 1/4" BSP (F) X 2 Nos.					XXX
if Required Other Process Connection Possible Through Adaptor						
Range						0/2 kg/cm ²
Refer range table						
Options						
CDD Custom designed dial	TND Tag No Marking on Dial					XXX
STP SS tag plate	CLC Calibration certificate					
DLG Dampening liquid glycerine filled	PY4 2" pipe/yoke mounting bracket (AISI 304 SS)					
MRP Maximum Reading Pointer With Plexi Glass						

Ordering Example: DP1 - XX - XX - X OR XX - XX - XXX - 0/2 kg/cm² - XXX

For other optional items, please contact factory for delivery and minimum quantity of order.

Note : Specifications and dimensions given in this product catalogue represents the state of engineering at the time of printing. Modifications may take place and materials specified may be replaced by others without prior notice.